

# KIEN1005G

## Industrial Ethernet Switch

### Hardware Installation Manual

***KYLAND***

Kyland Technology Co., LTD.

Publication Date: June 2011

Version: V1.0

Customer Service Hotline: (+8610) 88796676

FAX: (+8610) 88796678

Website: <http://www.kyland.cn>

E-mail: support@kyland.biz

No.: 1.12.02.1027-0

**KIEN1005G Industrial Ethernet Switch  
Hardware Installation Manual**

**Disclaimer: Kyland Technology Co., Ltd. tries to keep the content in this manual as accurate and as up-to-date as possible. This document is not guaranteed to be error-free, and we reserve the right to amend it without notice to users.**

**Copyright © 2011 KYLAND Technology CO., LTD.**

**All rights reserved.**

**No part of this documentation may be excerpted, reproduced, translated, annotated or duplicated, in any form or by any means without the prior written permission of KYLAND Corporation.**

## Notice for Safety Operation

This product performs reliably as long as it is used according to the guidance. Artificial damage or destruction of the equipment should be avoided.

- Read this manual carefully and keep it for future reference;
- Do not place the equipment near water sources or damp areas;
- Do not place anything on power cable and put the cable in unreachable places;
- Do not tie or wrap the cable to prevent fire.
- Power connectors and other equipment connectors should be firmly interconnected and checked frequently.
- Do not repair the equipment by yourself, unless it is clearly specified in the manual.
- Please keep the equipment clean; if necessary, wipe the equipment with soft cotton cloth.

In the following cases, please immediately cut off the power supply and contact our company:

- Water gets into the equipment;
- Equipment damage or shell breakage;
- Abnormal operation of equipment or its performances have completely changed;
- The equipment emits odor, smoke or abnormal noise.

## Contents

1. Packing List.....	5
2. Product Overview.....	5
3. Structure and Interface.....	5
4. Mounting.....	6
5. Cable Connection.....	10
6. LED Indicators.....	14
7. Product Models.....	14
8. Basic Features and Specifications.....	15

## 1. Packing List

KIEN1005G Industrial Ethernet Switch	1
Hardware Installation Manual	1
Certificate of Quality (including Warranty Card)	1

**Note:** After unpacking, please check the accessories and the appearance of the equipment. If anything is missing or damaged, please contact us.

## 2. Product Overview

KIEN1005G is a series of green low power consumption DIN-Rail industrial Ethernet switch that can be applied extensively in wind power, distribution network automation, and subway PIS, power SCADA, wastewater treatment, metallurgy, intelligent transportation, rail transit and many other industries.

KIEN1005G industrial Ethernet switch supports DIN-Rail and wall mounting. It provides five 10/100/1000Base-TX RJ45 ports in the front panel.

## 3. Structure and Interface

### ◆ Front Panel

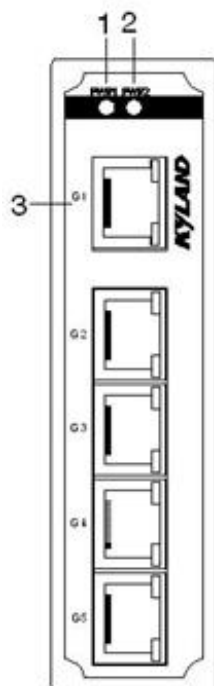

1: PWR1 -- Power 1 LED

2: PWR2 -- Power 2 LED

3: G1-G5 -- 10/100/1000Base-T(X) RJ45 ports

◆ **Top Panel**

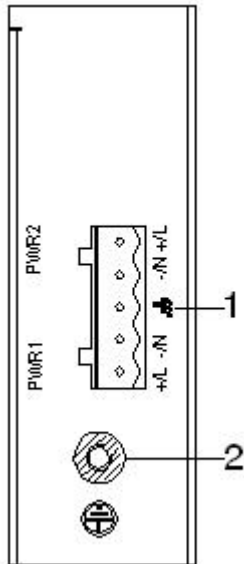

- 1: Terminal block for power input
- 2: Screw hole for grounding

**4. Mounting**

◆ **Dimension Drawing for DIN-Rail Mounting (Unit: mm)**

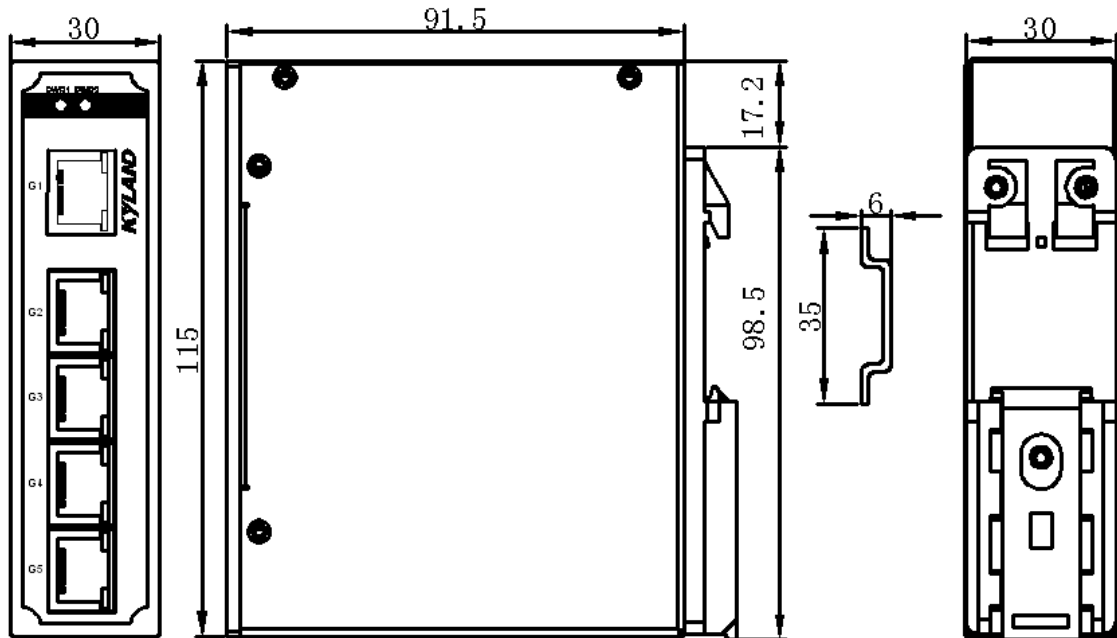

◆ **Dimension Drawing for Wall Mounting (Unit: mm)**

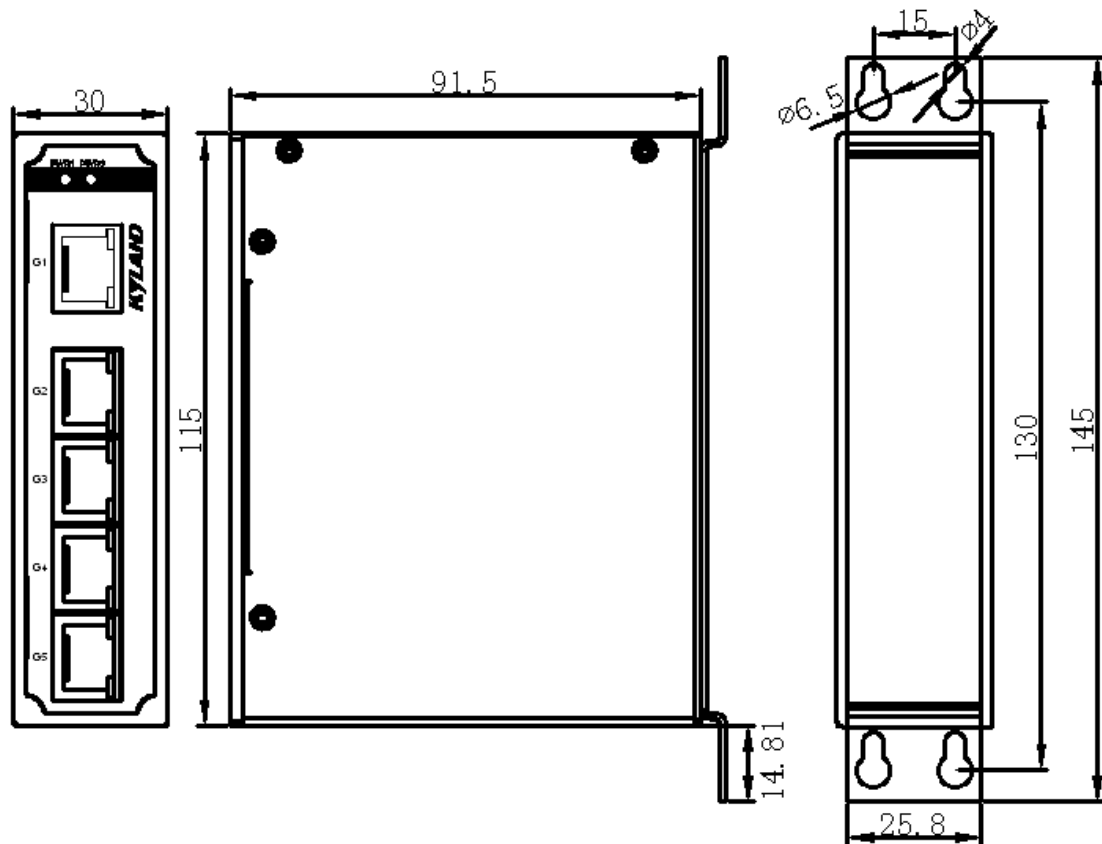

**Note:** The switch housing is a part of the heat dissipation system, which becomes hot during operation. Please avoid contact.

#### ◆ Mounting Steps

##### ● KIEN1005G DIN-Rail Mounting

The specific steps are as follows:

Step 1: Select the mounting position for KIEN1005G and ensure that there is enough space.

Step 2: Insert the top of the DIN-Rail into the spring-supported slot of the DIN-Rail connecting seat in the rear panel of KIEN1005G as seen below; move the device in the direction of arrow 2 to put the whole Din-Rail into the seat; check whether KIEN1005G is firmly mounted on the DIN-Rail, as shown below.

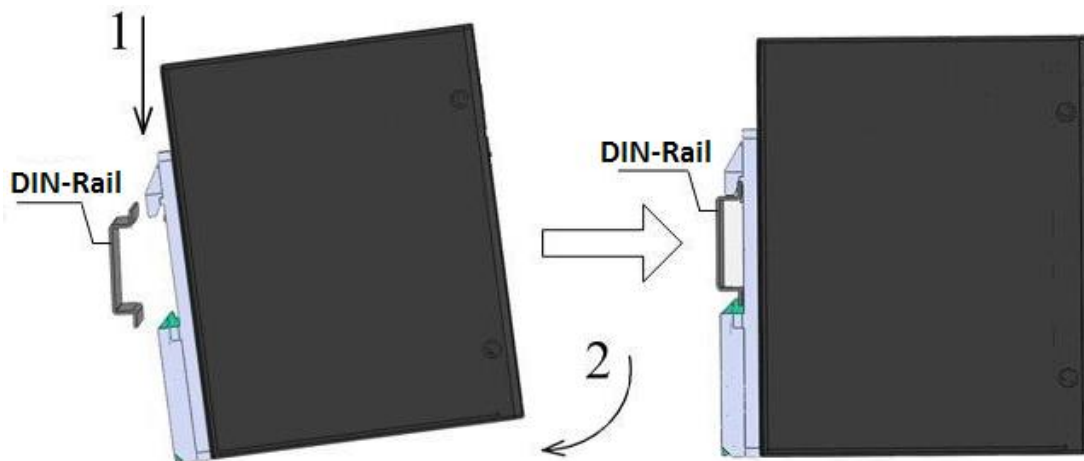

- **Remove KIEN1005G from DIN-Rail**

The specific steps are as follows:

Step 1: Plug the screwdriver into the hole at the bottom of spring locking plate; press the plate down to loosen the connection of DIN-Rail and switch, as shown in arrow 1

Step 2: Take up KIEN1005G in the direction of arrow 2; meanwhile remove the device from the DIN-Rail along the direction of arrow 3.

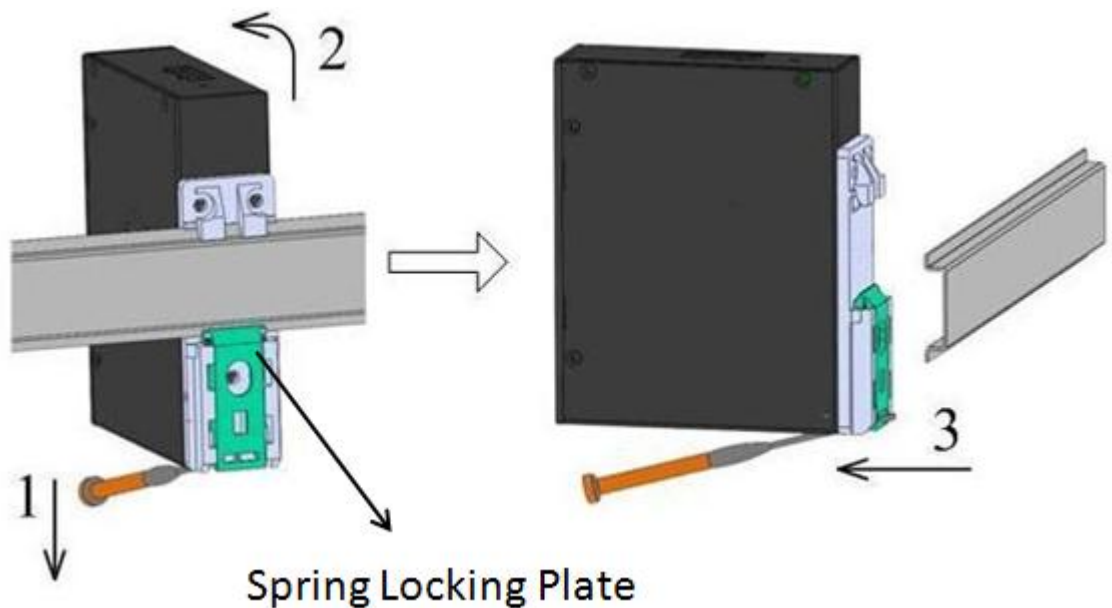

- **KIEN1005G Wall Mounting**

The specific steps are as follows:

Step 1: Select the mounting position for KIEN1005G on the wall or in cabinet; ensure that there is enough space for the switch.



Step 2: Drill 4 holes on the selected position according to the wall mounting dimension drawings; use a cross-screwdriver to screw 4 cross-slot screws (M3×10) into holes. Don't tighten up the screws completely; leave about 5mm of space between.

Step 3: Aim 4 mounting holes on KIEN1005G mounting plate at 4 fixed screws; pass the screws through 4 holes with the diameter of 6.5mm (Φ6.5); then slide down KIEN1005G as seen below; finally screw 4 screws tightly. Now the KIEN1005G should be firmly fixed to the wall or cabinet.

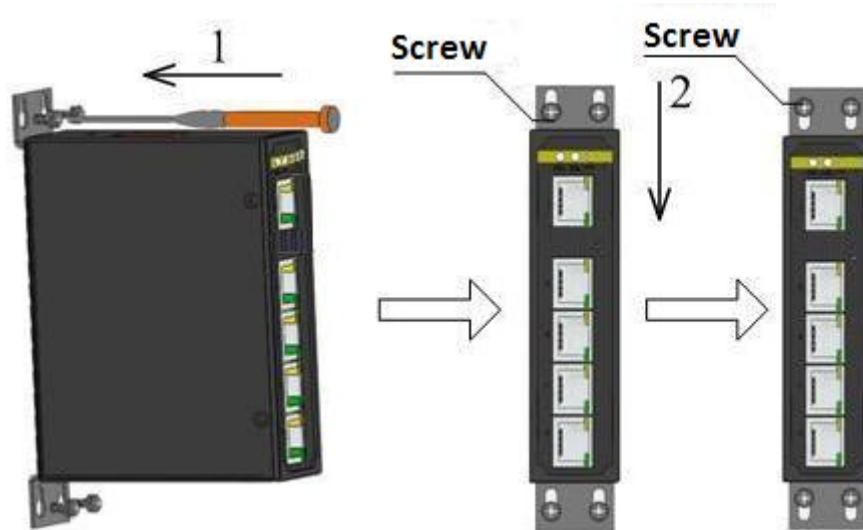

- **Remove KIEN1005G from wall or cabinet**

The specific steps are as follows:

Step 1: Use a screwdriver to loosen 4 screws; move the device up to let screws into 4 holes with the diameter of 6.5mm (Φ6.5).

Step 2: Unscrew the screws from wall or cabinet; remove the device from wall or cabinet

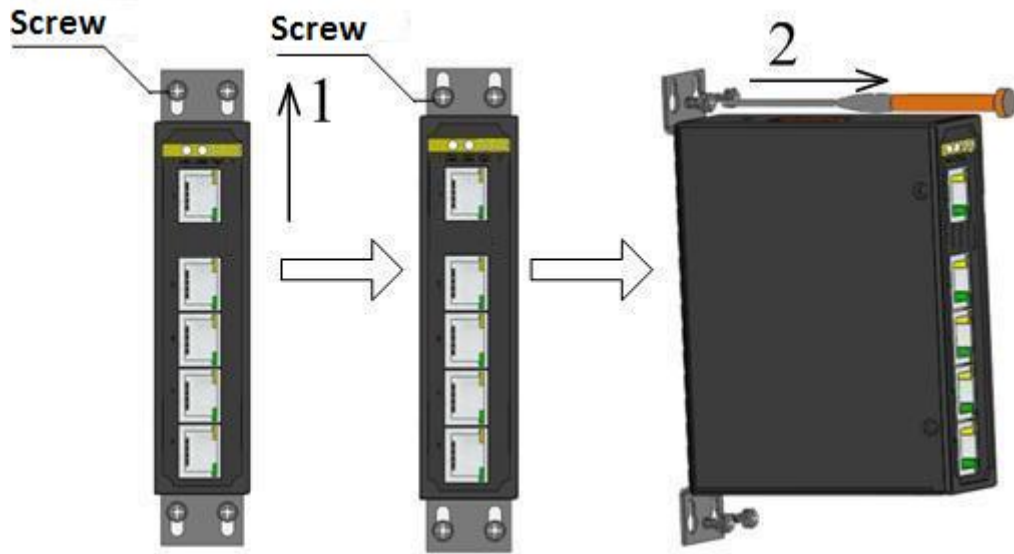

## 5. Cable Connection

### ◆ RJ45 Port

- **RJ45 port cable types and requirements**

10/100/1000Base-TX Ethernet RJ45 port can be connected to terminal equipment and network devices with straight-through cables or cross-over cables. RJ45 connectors must be equipped at both ends of cable.

**RJ45 connector and pin number:**

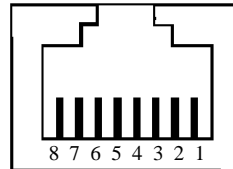

- **Pin distribution of 10/100/1000Base-TX**

Pin	MDI/MDI-X signal name
1	Output/Receiving data (TRD0+)
2	Output/Receiving data (TRD0-)
3	Output/Receiving data (TRD1+)
4	Output/Receiving data (TRD2+)
5	Output/Receiving data (TRD2-)
6	Output/Receiving data (TRD1-)
7	Output/Receiving data (TRD3+)
8	Output/Receiving data (TRD3-)

Note: "+" "-" means cable polarity.

● 1000M straight-through cable wiring

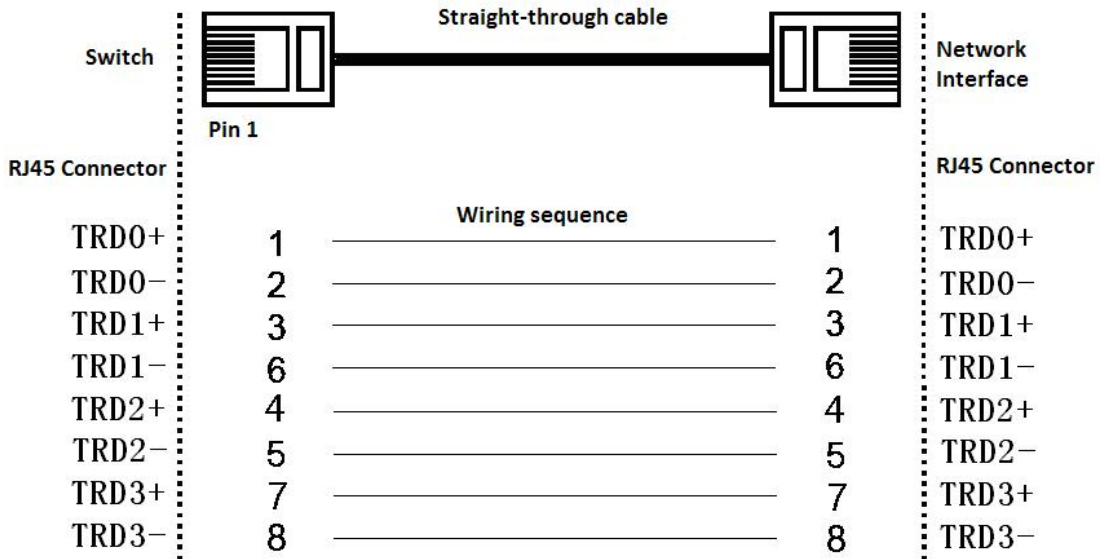

● 1000M cross-over cable wiring

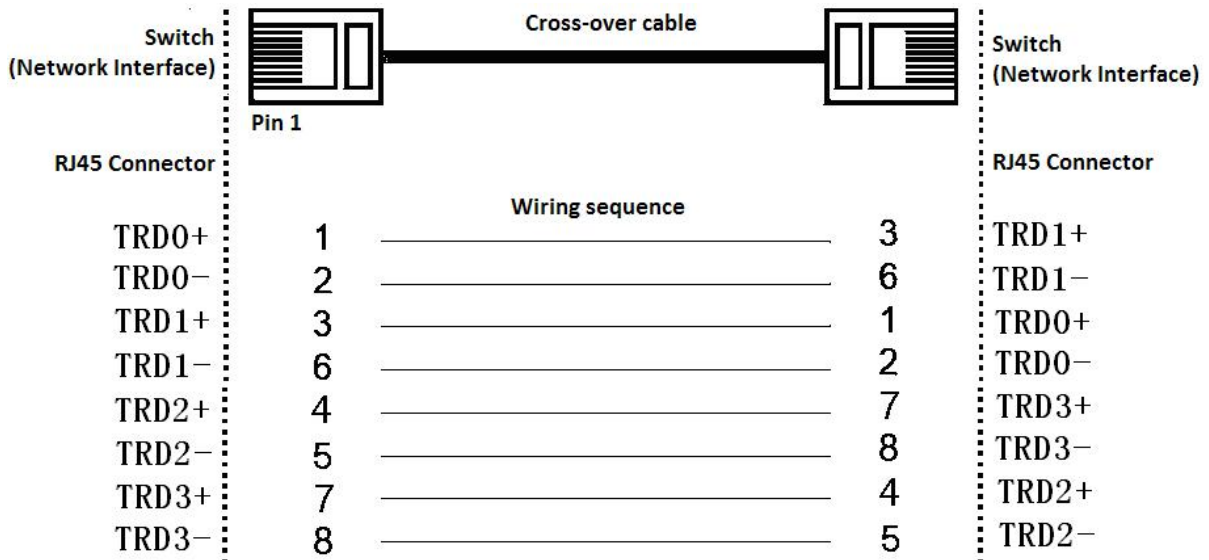

◆ Power

According to the power input requirements, use a 5.08mm-spacing terminal block to connect power cable.

**Note:** The cross section area of power cable is required to be greater than 0.75mm<sup>2</sup> and less than 2.5mm<sup>2</sup>. The grounding resistance requirement: <5Ω.

5 pin 5.08mm power terminal block:

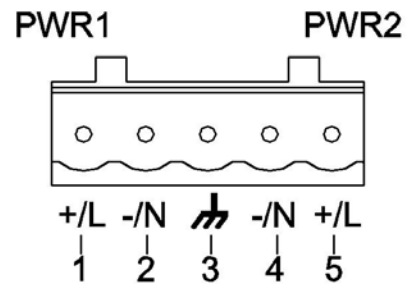

**Contact definition**

Contact number	DC wiring definition	AC wiring definition
1	PWR1: +	PWR1: L
2	PWR1: -	PWR1: N
3	Protection Ground	Protection Ground
4	PWR2: -	PWR2: N
5	PWR2: +	PWR2: L

- **Wiring and mounting**

Step 1: Take the power terminal block off KIEN1005G

Step 2: Insert the power cable into the terminal block and fix the power cable

Step 3: Put the terminal block back to KIEN1005G with the connected cable

- ◆ **Grounding**

- **Chassis grounding and power terminal grounding**

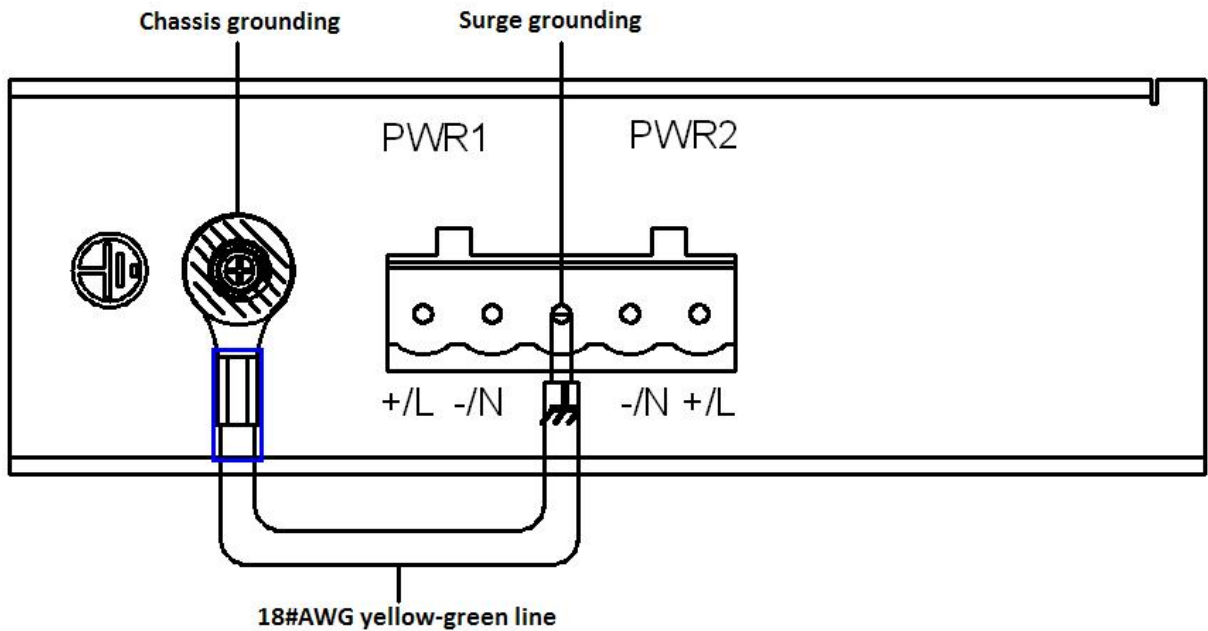

There is a grounding screw on the top panel of the KIEN1005G, which is for chassis grounding. One end of the chassis grounding cable is connected with the grounding screw and the other end of the cable is reliably earthed. (The cross section area of chassis grounding cable should be more than 2.5mm<sup>2</sup>. The grounding resistance requirement: <math><5\Omega</math>)

The grounding part in the 5.08mm power terminal block is called surge grounding.

It is required to connect the chassis grounding part with the surge grounding part by an 18#AWG yellow-green line as seen below

- 18#AWG yellow-green line (Unit: mm)

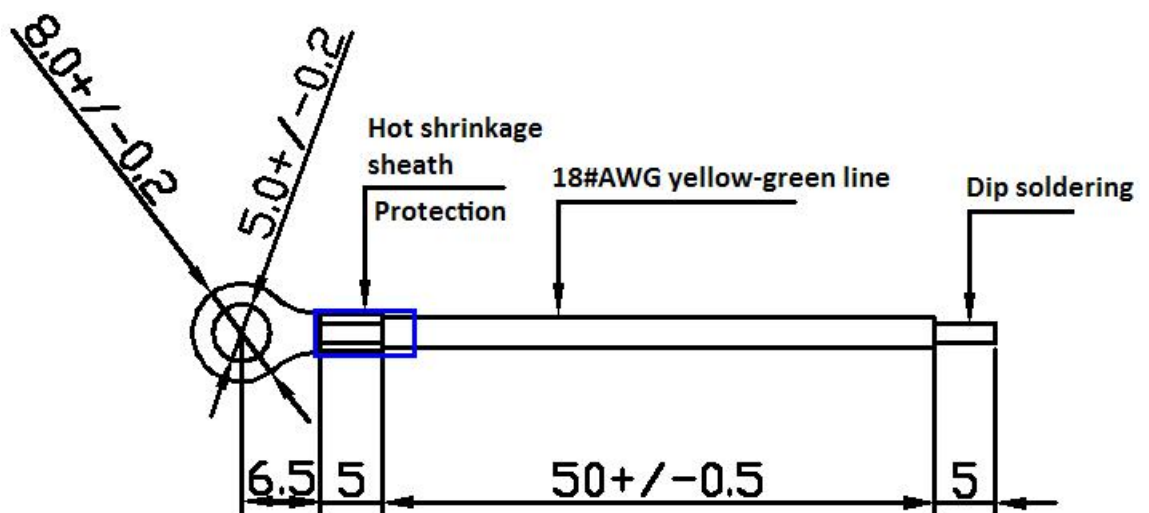

**Note:** If KEIN1005G needs to do a dielectric voltage withstand test, in order to avoid the failure of test, please disconnect the 18#AWG yellow-green line to disable surge protection circuit that connects to surge grounding.

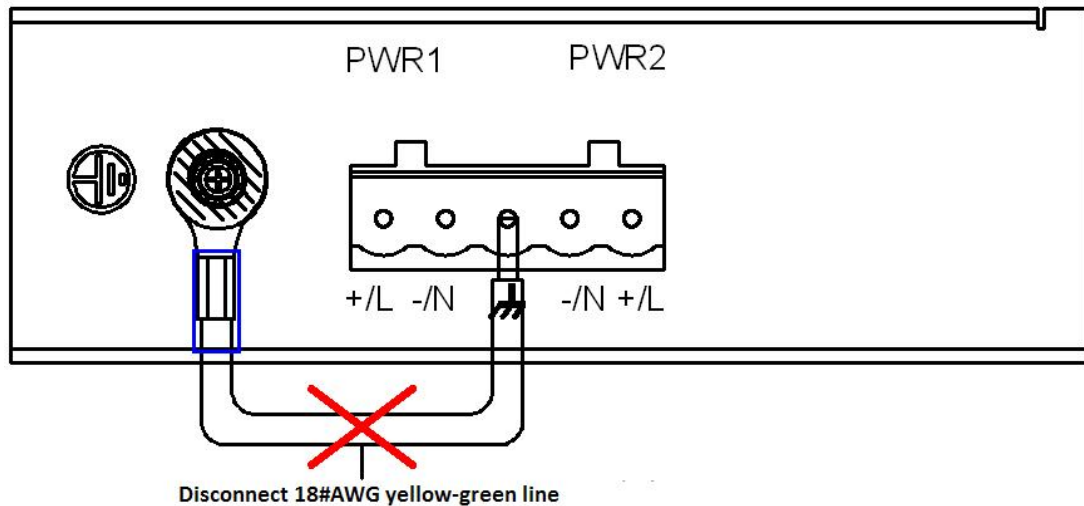

## 6. LED Indicators

KIEN1005G LED indicators

LED	State	Description
<b>Power LEDs</b>		
PWR1	ON	Power 1 connects and operates normally.
	OFF	Power 1 disconnects or operates abnormally.
PWR2	ON	Power 2 connects and operates normally.
	OFF	Power 2 disconnects or operates abnormally.
<b>Ethernet RJ45 port LEDs</b>		
Speed (Yellow)	ON	1000M working state (i.e. 1000Base-T)
	OFF	10/100M working state (i.e. 10/100Base-TX) or no connection
Link/Act (Green)	ON	Effective network connection in the port
	Blinking	Network activities in the port
	OFF	No effective network connection in the port

## 7. Product Models

The specific configuration models of KIEN1005G are shown in below table:

KIEN1005G Configuration Table

Model	Description	Power
KIEN1005G-5GE	5 10/100/1000Base-TX RJ45 Ports	12VDC, 24VDC/AC, dual redundant power inputs

## 8. Basic Features and Specifications

### ◆ Standard

IEEE 802.3i, IEEE 802.3u, IEEE 802.3ab, IEEE802.3z

### ◆ Industrial Standard

EMI: FCC CFR47 Part 15, EN55022/CISPR22, Class A

EMS: IEC61000-4-2(ESD): ±8KV (contact), ±15KV (air)

IEC61000-4-3(RS): 10V/m (80MHz-2GHz)

IEC61000-4-4(EFT): Power Port: ±4KV; Data Port: ±2KV

IEC61000-4-5(Surge) Power Port: ±2kV/DM, ±4kV/CM;

Data Port: ±2kV

IEC61000-4-6(CS):3V (10kHz-150kHz); 10V (150kHz-80MHz)

IEC61000-4-16 (common mode conduction): 30V (cont.), 300V (1s)

Machinery:

Vibration: IEC68-2-6, vibration amplitude:7mm, acceleration:20-15, frequency range: 2-9HZ 9-200HZ 200-500HZ

Shock: IEC68-2-27, duration of the half-sine pulse: 11ms, peak acceleration: 300m/s<sup>2</sup>

Free Fall: IEC68-2-32, Mass<20Kg: 0.25m

Industry: IEC61000-6-2

Railway: EN50155, EN50121-4

### ◆ Cable

Twisted Pair: 100m (Standard CAT5, CAT5e network cable)

### ◆ Power Requirements

Power input: 12VDC (9~36VDC), 24VDC/AC (18~72VDC, 13~50VAC)

Power terminal: 5-pin 5.08mm-spacing plug-in terminal block

Power consumption: full load: 3.4W; standby: 0.99W

◆ **Physical Characteristics**

Installation: DIN-Rail or wall mounting

Dimensions (W×H×D): 30mm×115mm×91.5mm

Weight: 0.76Kg

◆ **Environment Limits**

Operating Temperature: -40°C to 85°C (-40 to 185°F)

Storage Temperature: -40°C to 85°C (-40 to 185°F)

Ambient Relative Humidity: 5% to 95% (non-condensing)

◆ **MTBF:** 357000h

◆ **Warranty:** 5 years

For more information about KYLAND products, please visit our website:

<http://www.kyland.cn/>