

KIEN1009 Industrial Ethernet Switch

Hardware Installation Manual



KYLAND

Kyland Technology Co., Ltd.

Publication Date: Mar. 2013

Version: V1.0

FAX: +86-10-88796678

Website: <http://www.kyland.com>

E-mail: support@kyland.com

No.: 1.12.02.1049-0

KIEN1009 Industrial Ethernet Switch

Hardware Installation Manual

Disclaimer: Kyland Technology Co., Ltd. tries to keep the content of this manual as accurate and as updated as possible. This document is not guaranteed to be error-free, and we reserve the right to amend it without notice to users.

All rights reserved.

No part of this documentation may be excerpted, reproduced, translated, annotated or duplicated, in any form or by any means without the prior written permission of KYLAND Corporation.

Copyright © 2013 Kyland Technology Co., Ltd.

Notice for Safety Operation

The product performs reliably as long as it is used according to the guidance. Artificial damage or destruction of the device should be avoided. Before using the device, read this notice carefully for personal and equipment safety. Please keep the manual for further reference. Kyland is not liable to any personal or equipment damage caused by violation of this notice.

- Do not place the device near water sources or damp areas. Keep the ambient relative humidity within the range from 5% to 95% (non-condensing).
- Do not place the device in an environment with high magnetic field, strong shock, or high temperature. Keep the working and storage temperatures within the allowed range.
- Install and place the device securely and firmly.
- Please keep the device clean; if necessary, wipe it with a soft cotton cloth.
- Do not place any irrelevant materials on the device or cables. Ensure adequate heat dissipation and tidy cable layout without knots.
- Wear antistatic gloves or take other protective measures when operating the device.
- Avoid any exposed metal wires because they may be oxidized or electrified.
- Install the device in accordance with related national and local regulations.
- Before power-on, make sure the power supply is within the allowed range of the device. High voltage may damage the device.
- Power connectors and other connectors should be firmly interconnected.
- Do not plug in or out the power supply with wet hands. When the device is powered on, do not touch the device or any parts with wet hands.
- Before operating a device connected to a power cable, remove all jewelry (such as rings, bracelets, watches, and necklaces) or any other metal objects, because they may cause electric shock or burns.
- Do not operate the device or connect or disconnect cables during an electrical storm.
- Use compatible connectors and cables. If you are not sure, contact our sales or technical support personnel for confirmation.
- Do not disassemble the device by yourself. When an anomaly occurs, contact our sales or technical support personnel.
- If any part is lost, contact our sales or technical support personnel to purchase the substitute. Do not purchase parts from other channels.

- Dispose of the device in accordance with relevant national provisions, preventing environmental pollution.

In the following cases, please immediately shut down your power supply and contact your Kyland representative:

- Water gets into the equipment.
- Equipment damage or shell damage.
- Equipment operation or performance has abnormally changed.
- The equipment emits odor, smoke or abnormal noise.

Contents

1	Product Overview	1
2	Structure and Interface	2
2.1	Front Panel	2
2.2	Top Panel	5
3	Mounting	6
3.1	Dimension Drawing	6
3.2	Mounting Modes and Steps	7
3.2.1	DIN-Rail Mounting	7
3.2.2	Panel Mounting	8
4	Connection	10
4.1	10/100Base-T(X) Ethernet Port	10
4.2	100Base-FX Ethernet Port	11
4.3	1000Base-X, 10/100/1000Base-T(X) SFP Slot	12
4.3.1	Gigabit SFP Optical Module	12
4.3.2	Gigabit SFP Electrical Module	13
4.4	Grounding	14
4.5	Power Terminal Block	14
5	LEDs	18
6	Basic Features and Specifications	19

1 Product Overview

KIEN1009 includes a series of green low-consumption industrial Ethernet switches applicable to wind power, distribution network automation, subway PIS, power SCADA, sewage treatment, metallurgy, intelligent transportation, rail transit, and many other industries. KIEN1009 supports redundant DC and AC power input of wide voltage range and provides normal-temperature-range and wide-temperature-range models.

The series switches support DIN-rail and panel mounting. KIEN1009 provides up to six 10/100Base-T(X) Ethernet ports, two 100Base-FX Ethernet ports, and one 1000Base-X, 10/100/1000Base-T(X) SFP slot (gigabit SFP slot).

Table 1 KIEN1009 Models

Model	Port			Power Supply	Remarks
	Gigabit SFP slot	100Base-FX Ethernet port	10/100Base-T(X) Ethernet port		
KIEN1009-E-8T	--	--	8	24DC (single power supply)	Normal temperature range (0°C~60°C)
KIEN1009-8T	--	--	8	12DCW, 24DCW, (redundant power supply)	Wide temperature range (-40°C~85°C)
KIEN1009-1S/M-7T	--	1	7		
KIEN1009-2S/M-6T	--	2	6		
KIEN1009-3S/M-6T	--	3	6		
KIEN1009-1GX-2S/M-6T	1	2	6		



Note:

We reserve the right to amend the product information listed in this table without notice. To obtain the latest information, contact our sales or technical support personnel.

2 Structure and Interface



Caution:

It is recommended to purchase the port dustproof shield (optional) to keep ports clean and ensure switch performance.

2.1 Front Panel

- Front Panel of KIEN1009-E-8T

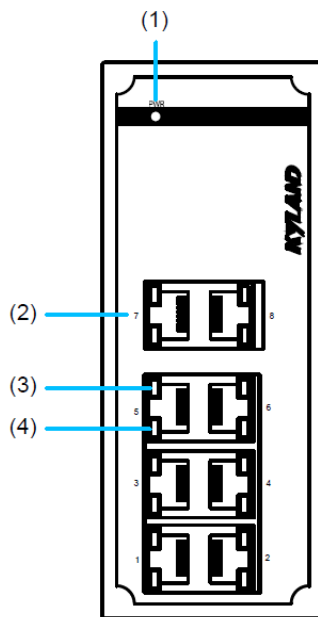

Figure 1 Front Panel of KIEN1009-E-8T

Table 2 Description of the Front Panel of KIEN1009-E-8T

No.	Identifier	Description
(1)	PWR	Power LED
(2)	1-8	Eight 10/100Base-T(X) Ethernet ports
(3)	--	10/100Base-T(X) Ethernet port speed LED (yellow)
(4)	--	10/100Base-T(X) Ethernet port connection status LED (green)

● Front Panel of KIEN1009-8T

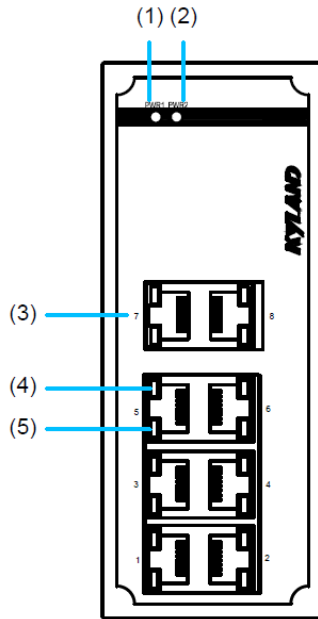

Figure 2 Front Panel of KIEN1009-8T

Table 3 Description of the Front Panel of KIEN1009-8T

No.	Identifier	Description
(1)	PWR1	Power 1 LED
(2)	PWR2	Power 2 LED
(3)	1-8	Eight 10/100Base-T(X) Ethernet ports
(4)	--	10/100Base-T(X) Ethernet port speed LED (yellow)
(5)	--	10/100Base-T(X) Ethernet port connection status LED (green)

● Front Panel of KIEN1009-1GX-2S/M-6T

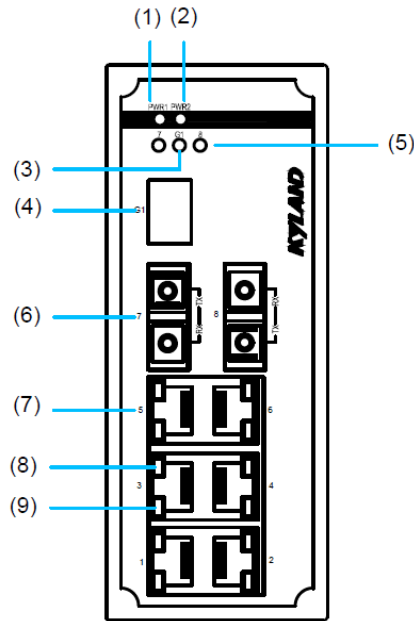

Figure 3 Front Panel of KIEN1009-1GX-2S/M-6T

Table 4 Description of the Front Panel of KIEN1009-1GX-2S/M-6T

No.	Identifier	Description
(1)	PWR1	Power 1 LED
(2)	PWR2	Power 2 LED
(3)	G1	Gigabit SFP slot connection status LED
(4)	G1	Gigabit SFP slot
(5)	7-8	100Base-FX Ethernet port connection status LEDs
(6)	7-8	Two 100Base-FX Ethernet ports
(7)	1-6	Six 10/100Base-T(X) Ethernet ports
(8)	--	10/100Base-T(X) Ethernet port speed LED (yellow)
(9)	--	10/100Base-T(X) Ethernet port connection status LED (green)

2.2 Top Panel

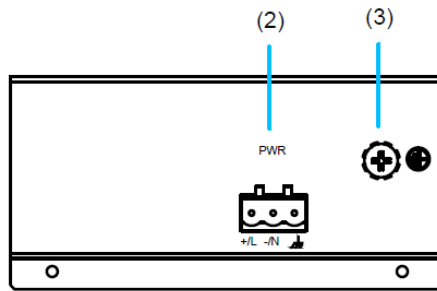

Figure 4 Top Panel 1

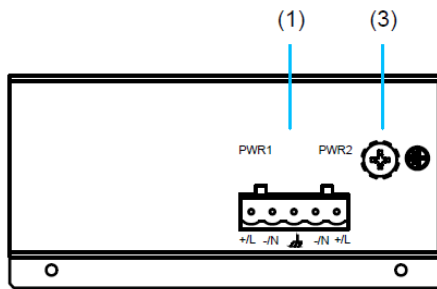

Figure 5 Top Panel 2

Table 5 Description of Top Panel

No.	Identifier	Description
(1)	<p>PWR1 PWR2</p>	Power terminal block
(2)	<p>PWR</p>	Power terminal block
(3)	--	Grounding screw



Note:

Top panel 1 is applicable to KIEN1009-E-8T.

Top panel 2 is applicable to KIEN1009-8T, KIEN1009-1S/M-7T, KIEN1009-2S/M-6T,

KIEN1009-3S/M-6T, and KIEN1009-1GX-2S/M-6T.

3 Mounting

3.1 Dimension Drawing

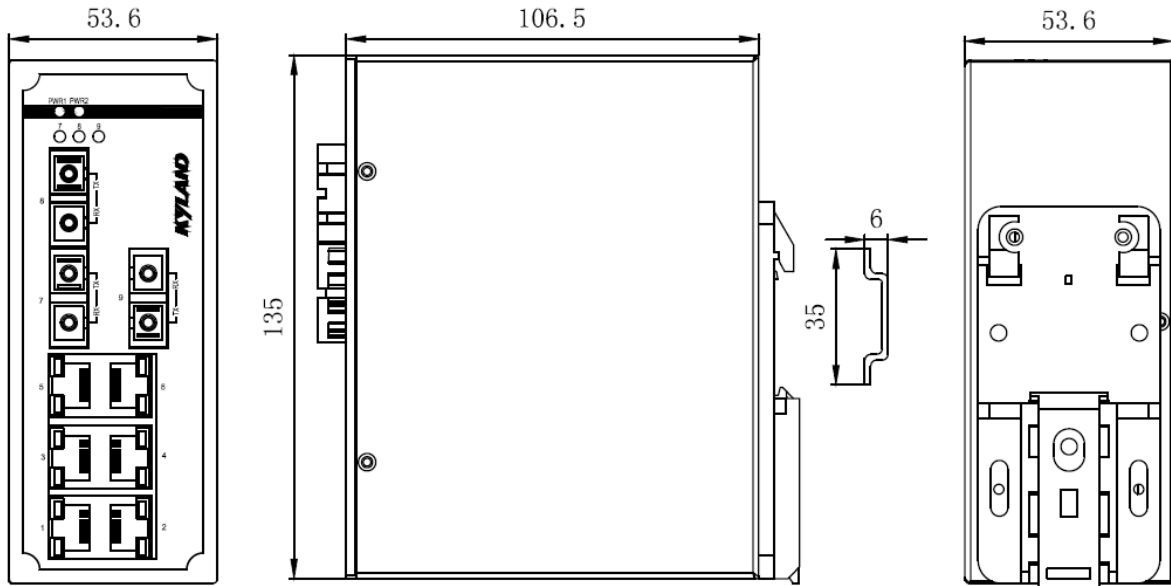

Figure 6 Dimensions for DIN-Rail Mounting (unit: mm)

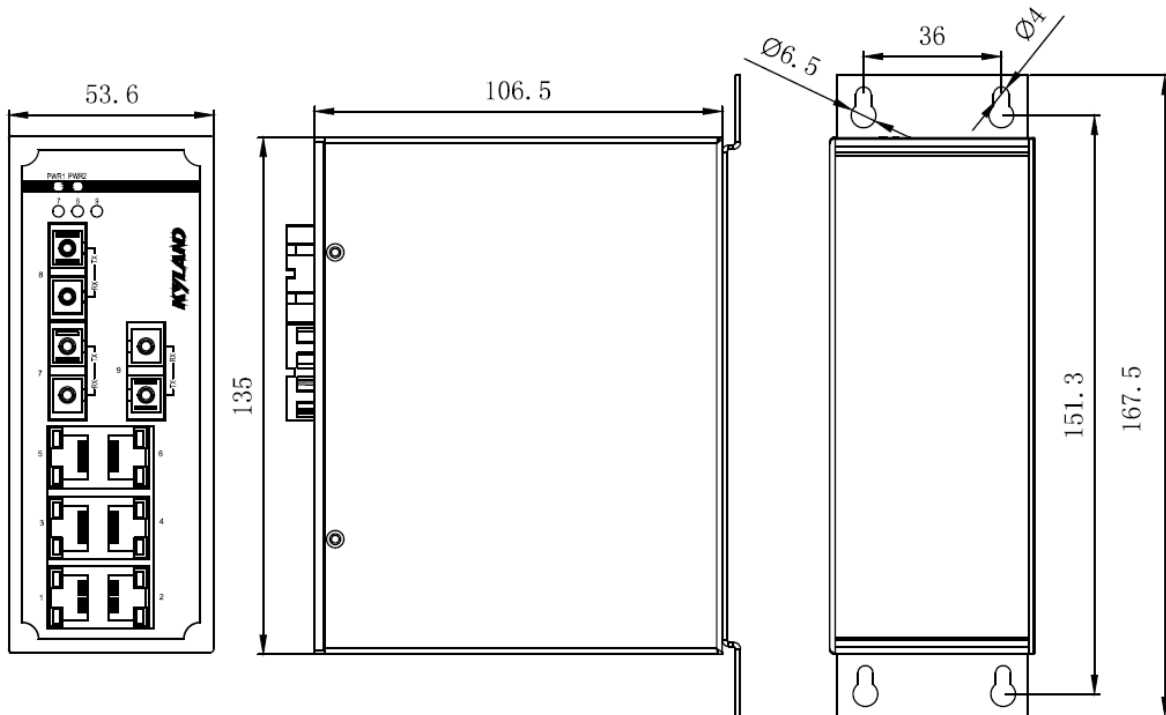

Figure 7 Dimensions for Panel Mounting (unit: mm)



Caution:

- As part of the heat dissipation system, the switch housing becomes hot during operation. Please use caution when coming in contact and avoid covering the switch housing when the switch is running.

- KIEN1009-3S/M-6T is used as an example to show the dimensions and mounting modes. The dimensions and mounting modes of other models are similar.

3.2 Mounting Modes and Steps

The series switches support DIN-rail and panel mounting. Before installation, make sure that the following requirements are met.

- 1) Environment: temperature (see Table 1), ambient relative humidity (5% to 95%, non-condensing)
- 2) Power requirement: The power input is within the voltage range of the switch.
- 3) Grounding resistance: $<5\Omega$
- 4) No direct sunlight, distant from heat source and areas with strong electromagnetic interference.

3.2.1 DIN-Rail Mounting

- Mounting

Step 1: Select the mounting position for the device and guarantee adequate space and heat dissipation (dimensions: 53.6mm×135mm×106.5mm).

Step 2: Insert the connecting seat onto the top of the DIN rail, and push the bottom of the device inward and upward to ensure the DIN rail fits in the connecting seat. Make sure the device is firmly installed on the DIN rail, as shown in the following figure.

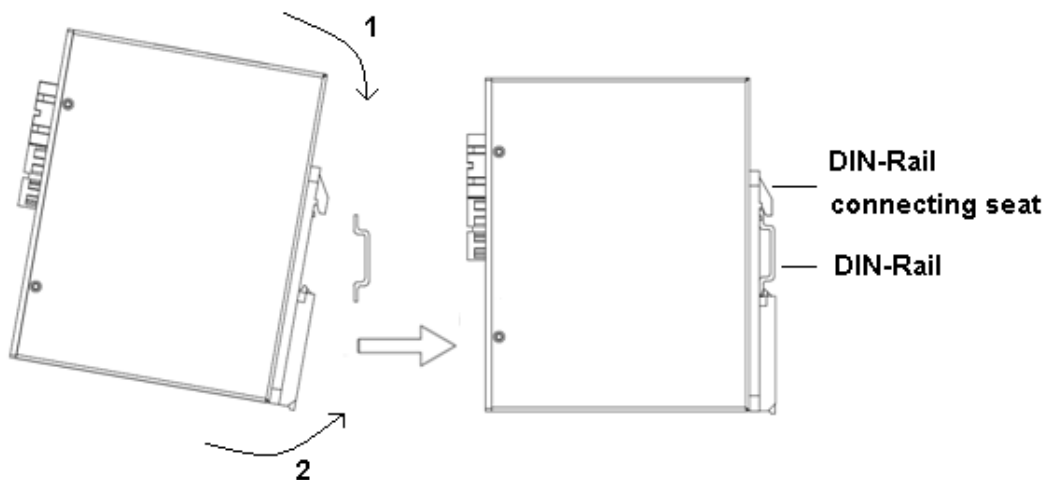

Figure 8 DIN-Rail Mounting

- Dismounting

Step 1: Insert the head of a screwdriver into the opening of the spring locking piece at the bottom from the left. Lift the handle of the screwdriver to open the spring locking piece of the connecting seat, as shown on the left of the following figure.

Step 2: Move the device in direction 2 until the bottom of the device is detached from the DIN rail. Then move the device in direction 3 and uplift the device until the top of the connecting seat is detached from the DIN rail.

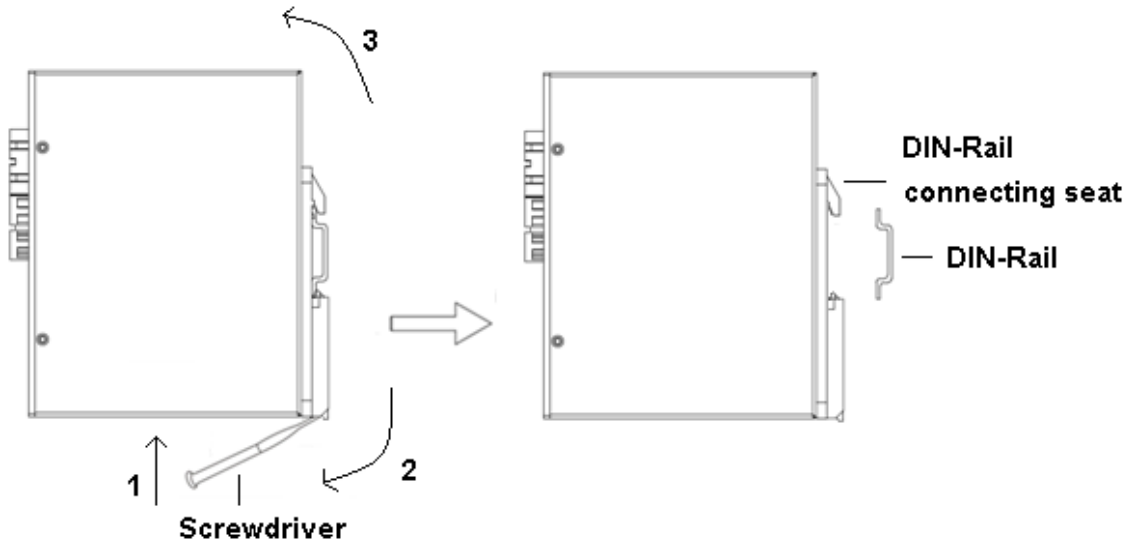

Figure 9 DIN-Rail Dismounting

3.2.2 Panel Mounting



Caution:

Purchase the plate (optional) for panel mounting.

- Mounting

Step 1: Use screws to secure the plate for panel mounting to the rear panel of the device.

Step 2: Select the mounting position (on a wall or inner wall of a cabinet) for the device and guarantee adequate space and heat dissipation (dimensions: 53.6mm×135mm×106.5mm).

Step 3: Punch four holes in the selected position according to the dimensions for panel mounting. Insert four screws into the four holes respectively, and turn the screws with a screwdriver until about a 5mm distance is left between each screw head and the wall.

Step 4: Align the four mounting holes on the plate for panel mounting with the four screws. Insert

the screws through the $\Phi 6.5$ positions in the following figure. Move the device in direction 1 until the screws are in the $\Phi 4$ positions. Then tighten the screws.

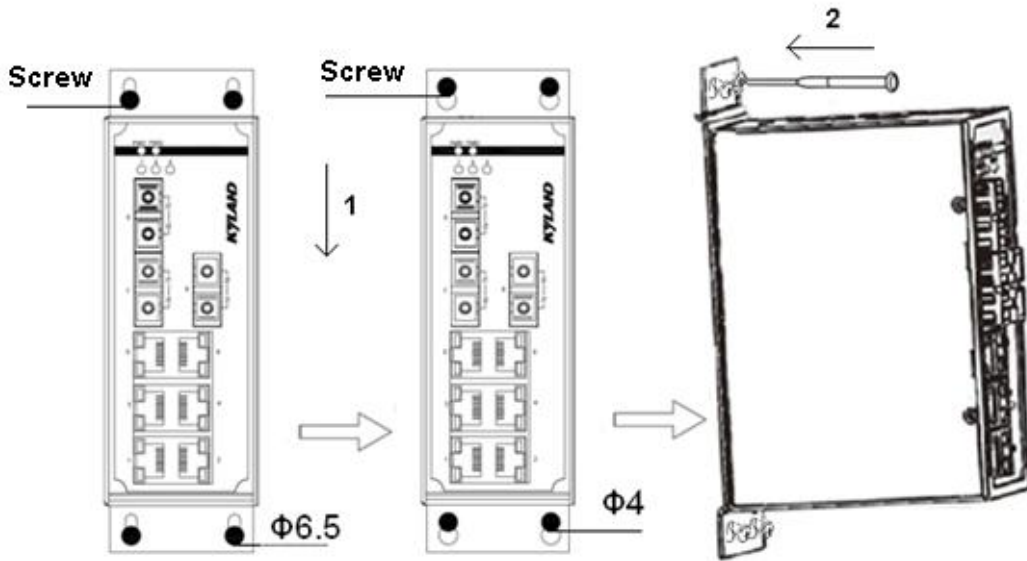

Figure 10 Panel Mounting

- Dismounting

Step 1: Loosen the four screws with a screwdriver. Pull the device upward until the four screws are in the $\Phi 6.5$ positions in the following figure. Then remove the plate for panel mounting from the four screws to detach the device from the wall or inner wall of the cabinet.

Step 2: Loosen the screws completely with a screwdriver. Remove them from the wall or inner wall of the cabinet. Then remove the plate for panel mounting from the rear panel to complete dismounting the device.

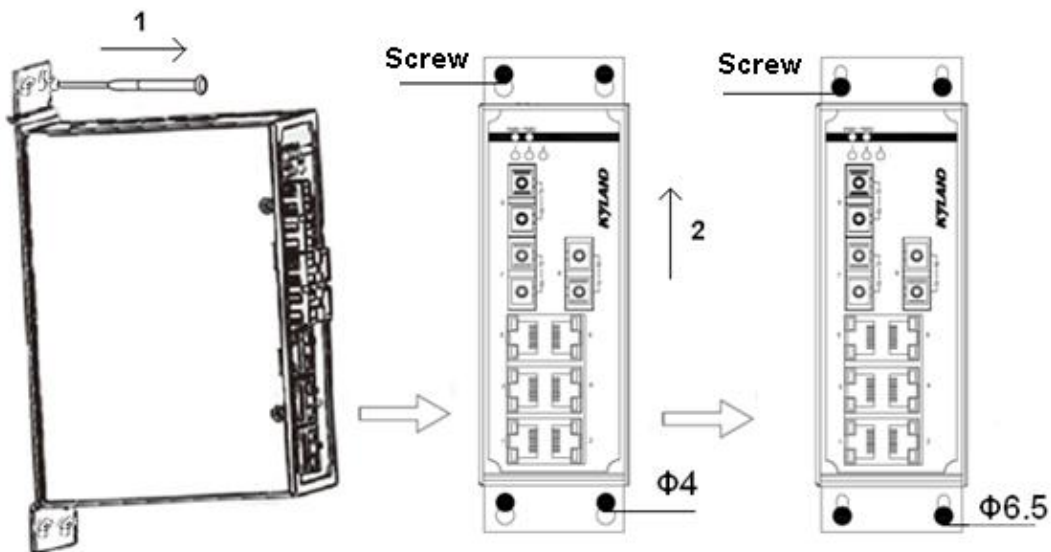

Figure 11 Panel Dismounting

4 Connection

4.1 10/100Base-T(X) Ethernet Port

10/100Base-T(X) Ethernet port is equipped with RJ45 connector. The port is self-adaptive. It can automatically configure itself to work in 10M or 100M state, full or half duplex mode. The port can also adapt to MDI or MDI-X connection automatically. You can connect the port to a terminal or network device with a straight-through or cross-over cable.

- Pin Definition

The following figure shows the pin numbers of the 10/100Base-T(X) RJ45 port.

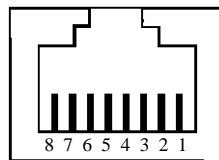

Figure 12 RJ45 Port

The following table lists the pin definitions of the 10/100Base-T(X) RJ45 port.

Table 6 Pin Definitions of 10/100Base-T(X) RJ45 Port

Pin	MDI-X Signal	MDI Signal
1	Receive Data+ (RD+)	Transmit Data+ (TD+)
2	Receive Data- (RD-)	Transmit Data- (TD-)
3	Transmit Data+ (TD+)	Receive Data+ (RD+)
6	Transmit Data- (TD-)	Receive Data- (RD-)
4, 5, 7, 8	Unused	Unused



Note:

"+" and "-" indicate level polarities.

- Wiring Sequence

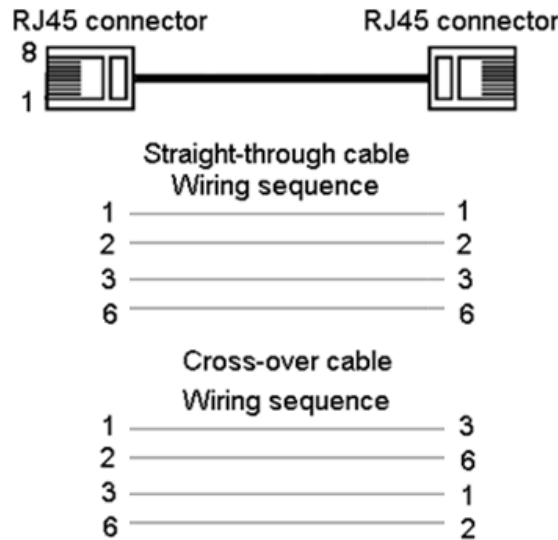

Figure 13 Connection Using Straight-through/Cross-over Cable



Note:

The color of the cable for RJ45 connector meets the 568B standard: 1-orange and white, 2-orange, 3-green and white, 4-blue, 5-blue and white, 6-green, 7-brown and white, and 8-brown.

4.2 100Base-FX Ethernet Port

100Base-FX Ethernet port is equipped with FC/ST/SC connector, and each port consists of TX (transmit) port and RX (receive) port. To enable data transmission between Device A and Device B, connect the TX port of Device A to the RX port of Device B, and the RX port of Device A to the TX port of Device B. The following uses an SC port as an example. The wiring sequence of an ST/FC port is the same with that of the SC port.

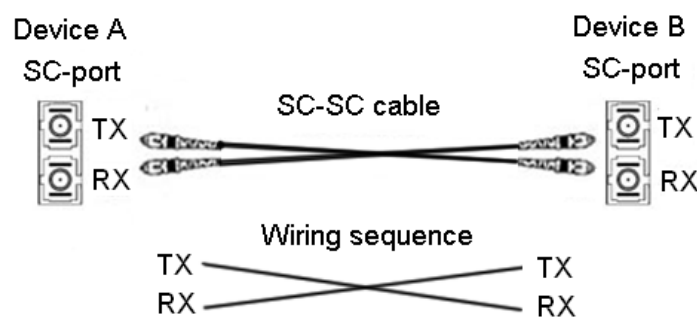

Figure 14 Connection of 100Base-FX Ethernet Port



Caution:

The device uses laser to transmit signals in fibers. The laser meets the requirements of level 1 laser products. Routine operation is not harmful to your eyes, but do not look directly at the fiber port when the device is powered on.

4.3 1000Base-X, 10/100/1000Base-T(X) SFP Slot

1000Base-X, 10/100/1000Base-T(X) SFP slot (gigabit SFP slot) requires an SFP optical/electrical module to enable data transmission. The following table lists the gigabit SFP optical/electrical modules (optional) supported by the series switches.

Table 7 Gigabit SFP Optical/Electrical Modules

Model	Port	MM/SM	Connector	Central Wavelength	Transmission Distance
IGSFP-M-SX-LC-850-0.55	1000Base-X port	MM	LC	850nm	0.55km
IGSFP-S-LX-LC-1310-10	1000Base-X port	SM	LC	1310nm	10km
IGSFP-S-LH-LC-1310-40	1000Base-X port	SM	LC	1310nm	40km
IGSFP-S-ZX-LC-1550-80	1000Base-X port	SM	LC	1550nm	80km
IGSFP-10/100/1000BASE-T-RJ45	10/100/1000Base-T(X) port	--	RJ45	--	--

4.3.1 Gigabit SFP Optical Module

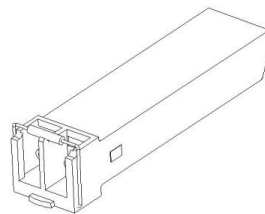

Figure 15 Gigabit SFP Optical Module

An SFP optical module is equipped with LC connector, and each port consists of a TX (transmit) port and an RX (receive) port. To enable communication between Device A and Device B, connect the TX port of Device A to the RX port of Device B, and the RX port of Device A to the TX port of Device B, as shown in the following figure.

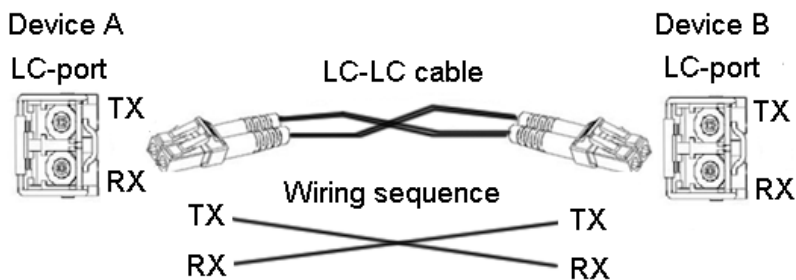

Figure 16 Fiber Connection of the SFP Optical Module

- How to Connect the SFP Optical Module

Insert the SFP optical module into the SFP slot in the switch, and then insert the fibers into the TX port and RX port of the SFP module.

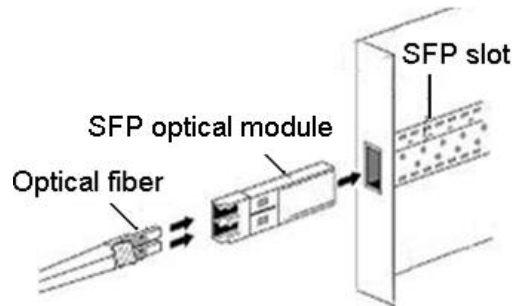

Figure 17 Connecting the SFP Optical Module

Identify the RX port and TX port of an SFP optical module:

1. Insert the two connectors in one end of two fibers into the SFP module, and those in the other end into the peer module.
2. View the corresponding connection status LED:

If the LED is on, the connection is correct. If the LED is off, the link is not connected. This may be caused by incorrect connection of the TX and RX ports. In this case, swap the two connectors at one end of the fibers.



Caution:

- The device uses laser to transmit signals in fibers. The laser meets the requirements of level 1 laser products. Routine operation is not harmful to your eyes, but do not look directly at the fiber port when the device is powered on.
- If the defined transmission distance of an SFP module is longer than 60km, do not use a short fiber (<20km) for connection. If such a short fiber is used, the module will be burned.

4.3.2 Gigabit SFP Electrical Module

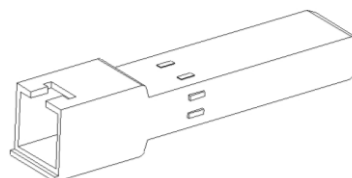

Figure 18 Gigabit SFP Electrical Module

- How to Connect the SFP Electrical Module

Insert the SFP electrical module into the SFP slot in the switch, and then insert the RJ45 connector of the twisted pair into the SFP module.

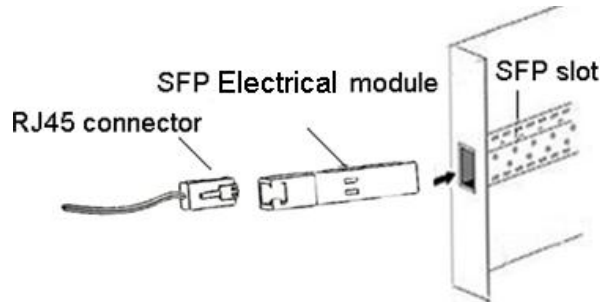

Figure 19 Connecting the SFP Electrical Module

4.4 Grounding

Grounding protects the switch from lightning and interference. Therefore, you must ground the switch properly. You need to ground the switch before it is powered on and disconnect the grounding cable after the switch is powered off.

The switch provides a grounding screw on the top panel for chassis grounding. After crimping one end of the grounding cable to a cold pressed terminal, secure the end to the grounding screw and connect the other end to the earth firmly.

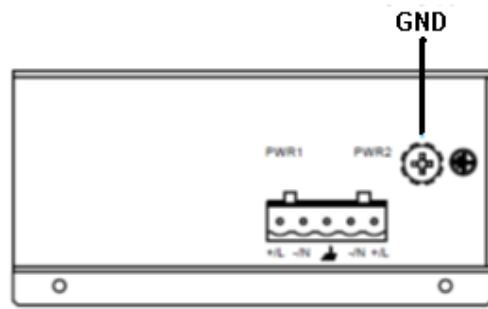

Figure 20 Grounding



Note:

Cross-sectional area of the chassis grounding cable > 2.5mm²; grounding resistance < 5Ω

4.5 Power Terminal Block

There is a power terminal block on the top panel of the device. You need to connect the power wires to the terminal block to provide power for the device. The device supports single power supply with 3-pin 5.08mm-spacing plug-in terminal block and redundant power supply with 5-pin 5.08mm-spacing plug-in terminal block. When the redundant power supply is used and one

power input is faulty, the device can continue operating properly, thereby improving network reliability.



Note:

0.75mm²<Cross-sectional area of the power wire<2.5mm²; grounding resistance<5Ω

- 3-Pin 5.08mm-Spacing Plug-in Terminal Block (single power input)

The following figure shows the 3-pin 5.08mm-spacing plug-in terminal block.

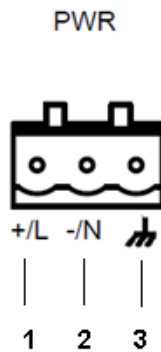

Figure 21 3-Pin 5.08mm-Spacing Plug-in Terminal Block (socket)

The following table lists the pin definitions of the 3-pin 5.08mm-spacing plug-in terminal block.

Table 8 Pin Definitions of 3-Pin 5.08mm-Spacing Plug-in Terminal Block

No.	DC Definition	AC Definition
1	PWR: +	PWR: L
2	PWR: -	PWR: N
3	PGND	PGND

- 5-Pin 5.08mm-Spacing Plug-in Terminal Block (redundant power input)

The following figure shows the 5-pin 5.08mm-spacing plug-in terminal block.

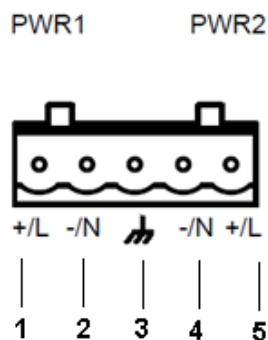

Figure 22 5-Pin 5.08mm-Spacing Plug-in Terminal Block (socket)

The following table lists the pin definitions of the 5-pin 5.08mm-spacing plug-in terminal block.

Table 9 Pin Definitions of 5-Pin 5.08mm-Spacing Plug-in Terminal Block

No.	DC Definition	AC Definition
1	PWR1: +	PWR1: L
2	PWR1: -	PWR1: N
3	PGND	PGND
4	PWR2: -	PWR2: N
5	PWR2: +	PWR2: L

● **Wiring and Mounting**

Step 1: Ground the device properly according to section 4.4.

Step 2: Remove the power terminal block from the device.

Step 3: Insert the power wires into the power terminal block according to Table 8 or Table 9, and secure the wires.

Step 4: Insert the terminal block with the connected wires into the terminal block socket on the device.

Step 5: Connect the other end of the power wires to the external power supply system according to the power supply requirements of the device. View the status of the power LEDs on the front panel. If the LEDs are on, the power is connected properly.

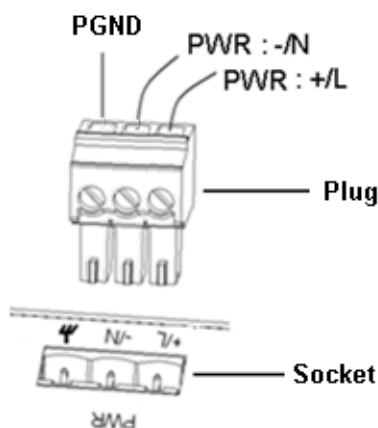

Figure 23 Connection of 3-Pin 5.08mm-Spacing Plug-in Terminal Block

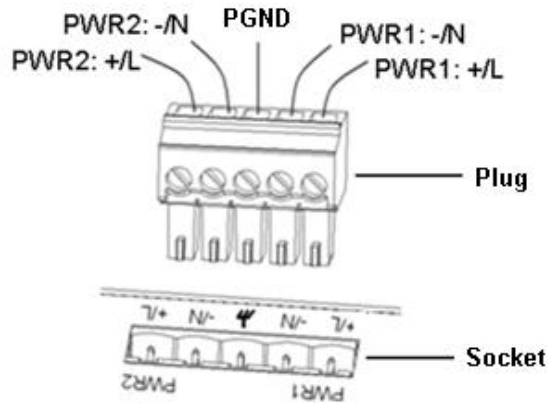

Figure 24 Connection of 5-Pin 5.08mm-Spacing Plug-in Terminal Block



Caution:

KIEN1009-E-8T supports 24DC power input and the other models support 12DCW and 24DCW power input. Before connecting the device to power supply, make sure that the power input meets the power requirement. If connected to an incorrect power input, the device may be damaged.



Warning:

- Do not touch any exposed conducting wire, terminal, or component with a voltage warning sign, because it may cause damage to humans.
- Do not remove any part or plug in or out any connector when the device is powered on.

5 LEDs

Table 10 LEDs

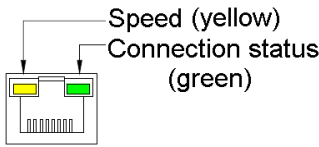
LED	State	Description
Power LED (applicable to single power supply)	On	The power is connected and operates properly.
	Off	The power is not connected or operates abnormally.
Power 1 LED (applicable to redundant power supply)	On	Power 1 is connected and operates properly.
	Off	Power 1 is not connected or operates abnormally.
Power 2 LED (applicable to redundant power supply)	On	Power 2 is connected and operates properly.
	Off	Power 2 is not connected or operates abnormally.
100Base-FX Ethernet port connection status LED	On	Effective port connection
	Blinking	Ongoing network activities
	Off	No effective port connection
Gigabit SFP slot connection status LED	On	Effective port connection
	Blinking	Ongoing network activities
	Off	No effective port connection
		
10/100Base-T(X) Ethernet port speed LED (yellow)	On	100M working state (100Base-TX)
	Off	10M working state (10Base-T) or no connection
10/100Base-T(X) Ethernet port connection status LED (green)	On	Effective port connection
	Blinking	Ongoing network activities
	Off	No effective port connection

6 Basic Features and Specifications

Power Requirements

Power Identifier	Rated Voltage Range	Maximum Voltage Range
12DCW	12-24VDC	9-36VDC
24DC	24VDC	18-36VDC
24DCW	24-48VDC	18-72VDC
Terminal block	3-pin 5.08mm-spacing plug-in terminal block, 5-pin 5.08mm-spacing plug-in terminal block	

Rated Power Consumption

Rated power consumption	6.5W (MAX)
-------------------------	------------

Physical Characteristics

Housing	Aluminum, fanless
Installation	DIN-rail mounting and panel mounting
Dimensions (W×H×D)	53.6mm×135mm×106.5mm (excluding connectors, DIN rail, and plate for panel mounting)
Weight	0.76Kg

Environmental Limits

Operating temperature	0°C~60°C	KIEN1009-E-8T
	-40°C~+85°C	KIEN1009-8T, KIEN1009-1S/M-7T KIEN1009-2S/M-6T, KIEN1009-3S/M-6T KIEN1009-1GX-2S/M-6T
Storage temperature	-40°C~+85°C	
Ambient relative humidity	5%~95% (non-condensing)	

MTBF

MTBF	397,000 hours
------	---------------

Warranty

Warranty	5 years
----------	---------

For more information about KYLAND products, please visit our website: <http://www.kyland.com>