

**KIEN3016A**  
**Industrial Ethernet Switch**  
**Hardware Installation Manual**



**KYLAND**  
**Kyland Technology Co., LTD.**

Publication Date: Oct. 2011

Version: V1.0

Customer Service Hotline: (+8610) 88796676

FAX: (+8610) 88796678

Website: <http://www.kyland.cn>

E-mail: support@kyland.biz

No.: 1.12.02.1030-0

**KIEN3016A Industrial Ethernet Switch  
Hardware Installation Manual**

**Disclaimer:** Kyland Technology Co., Ltd. tries to keep the content in this manual as accurate and as up-to-date as possible. This document is not guaranteed to be error-free, and we reserve the right to amend it without notice to users.

**All rights reserved.**

No part of this documentation may be excerpted, reproduced, translated, annotated or duplicated, in any form or by any means without the prior written permission of KYLAND Corporation.

**Copyright ©2011 KYLAND Technology CO., LTD.**

## Notice for Safety Operation

This product performs reliably as long as it is used according to guidelines. Artificial damage or destruction of the equipment should be avoided.

- Read this manual carefully and keep it for future reference;
- Do not place the equipment near water sources or damp areas;
- Do not place anything on power cable and put the cable in unreachable places;
- Do not tie or wrap the cable to prevent fire.
- Power connectors and other equipment connectors should be firmly interconnected and checked frequently.
- Do not repair the equipment by yourself, unless it is clearly specified in the manual.
- Please keep the equipment clean; if necessary, wipe the equipment with soft cotton cloth.

In the following cases, please immediately cut off the power supply and contact our company:

- Water gets into the equipment;
- Equipment damage or shell breakage;
- Equipment operation or performance has abnormally changed;
- The equipment emits odor, smoke or abnormal noise.

## Contents

1. Packing List.....	5
2. Product Overview .....	5
3. Structure and Interface .....	5
3.1 Front Panel.....	5
3.2 Top Panel.....	7
4. Mounting.....	7
4.1 Mounting .....	7
4.2 Mounting Steps.....	8
5. Cable Connection .....	11
5.1 10/100Base-T(X).....	11
5.2 100Base-FX.....	12
5.3 Power.....	13
5.4 Grounding.....	14
6. LED Indicators.....	16
7. Product Models and Accessories.....	17
8. Basic Features and Specifications.....	18

## 1. Packing List

KIEN3016A Industrial Ethernet Switch	1
Hardware Installation Manual	1
Certificate of Quality (including Warranty Card)	1

---

**Note:** After unpacking, please check the accessories and the appearance of the equipment. If anything is missing or damaged, please contact us.

---

## 2. Product Overview

KIEN3016A is a series of green, low power consumption and compact DIN-Rail industrial Ethernet switch that can be applied extensively in wind power, distribution network automation, subway PIS, power SCADA, wastewater treatment, metallurgy, intelligent transportation, rail transit and many other industries.

KIEN3016A industrial Ethernet switch supports DIN-Rail and panel mounting. It supports IP40 protection class.

## 3. Structure and Interface

### 3.1 Front Panel

KIEN3016A supports two kinds of product models. The interface is different for each product model.

- KIEN3016A-2S/M-14T front panel is shown in Figure 1 below

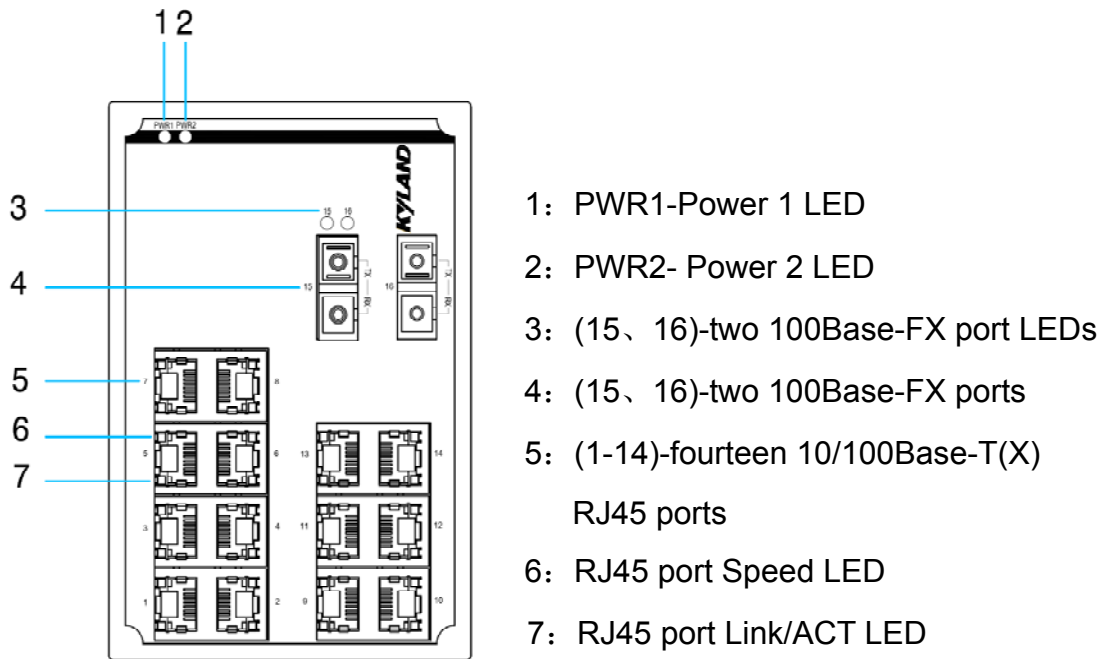

Figure 1 Front Panel 1

- KIEN3016A-16T front panel is shown in
- Figure 2 below

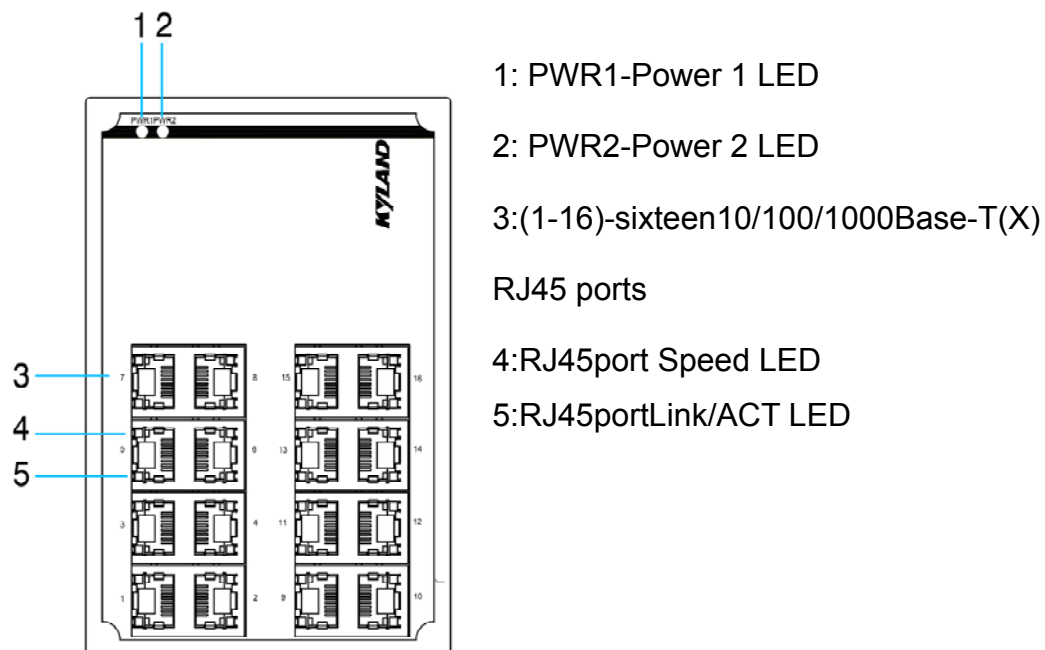
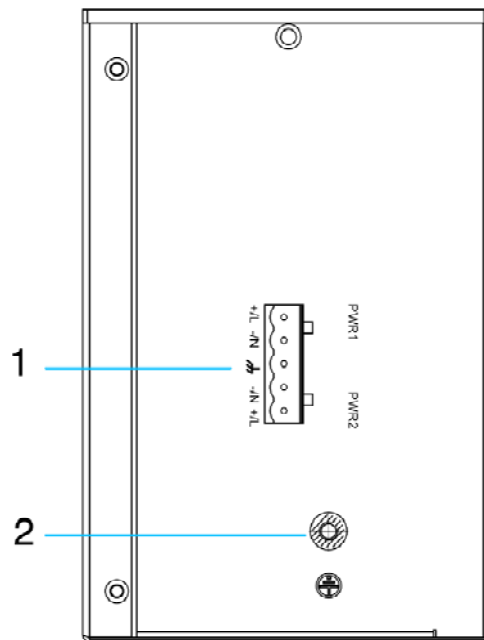

Figure 2 Front Panel 2

### 3.2 Top Panel



1: Terminal block for power input

2: Screw hole for grounding

Figure 3 Top Panel

## 4. Mounting

### 4.1 Mounting

- Dimension Drawing for DIN-Rail Mounting (Unit: mm)

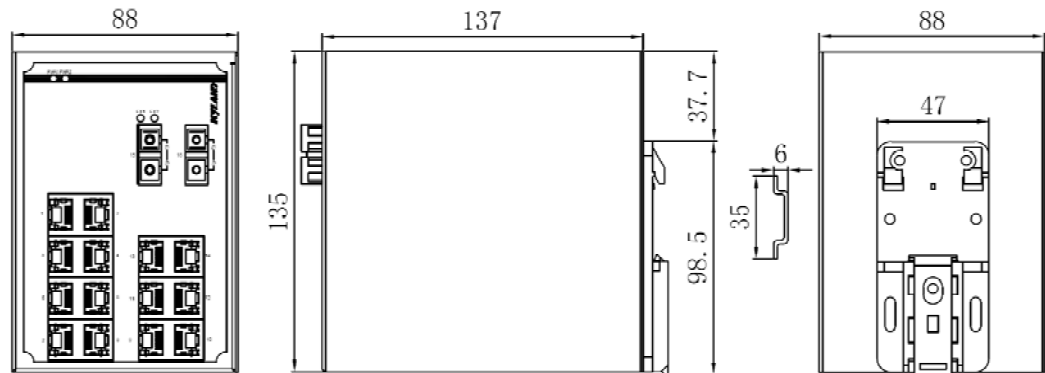

Figure 4 DIN-Rail Mounting

- Dimension Drawing for Panel Mounting (Unit: mm)

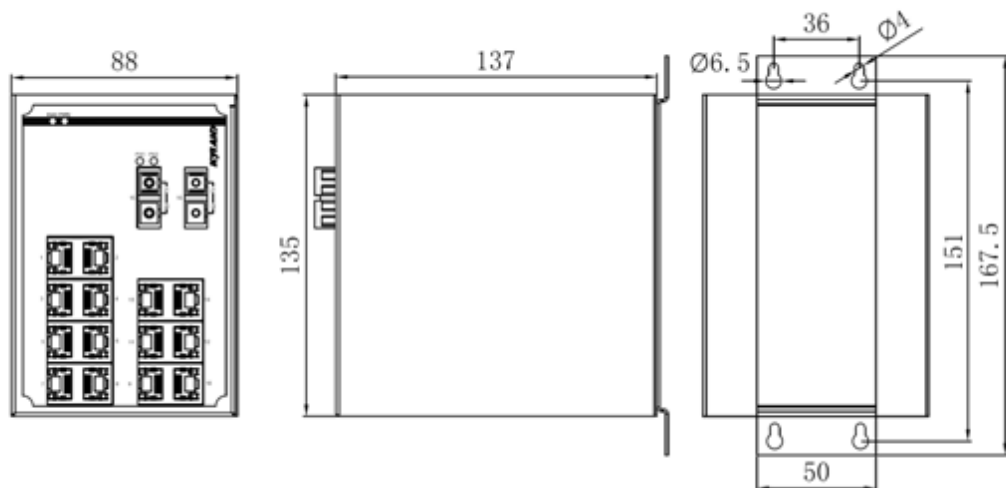

Figure 5 Panel Mounting

## 4.2 Mounting Steps

- KIEN3016A DIN-Rail Mounting

The specific steps are as follows:

Step 1: Select the mounting position for KIEN3016A and ensure that there is adequate space.

Step 2: Insert the top of the DIN-Rail into the spring-supported slot of the



DIN-Rail connecting seat in the rear panel of KIEN3016A as seen below; move the device in the direction of arrow 2 to put the whole Din-Rail into place; verify the KIEN3016A is firmly mounted on the DIN-Rail, as shown below.

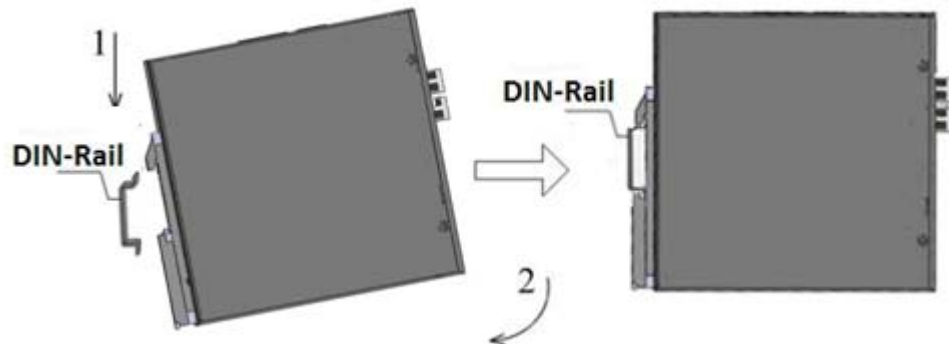

Figure 6 DIN-Rail Mounting

- Remove KIEN3016A from DIN-Rail

The specific steps are as follows:

Step 1: Place the screwdriver into the hole at the bottom of spring locking plate; press the plate down to loosen the connection of DIN-Rail and switch, as shown in arrow 1.

Step 2: Pull the KIEN3016A up in the direction of arrow 2; meanwhile remove the device from the DIN-Rail along the direction of arrow 3.

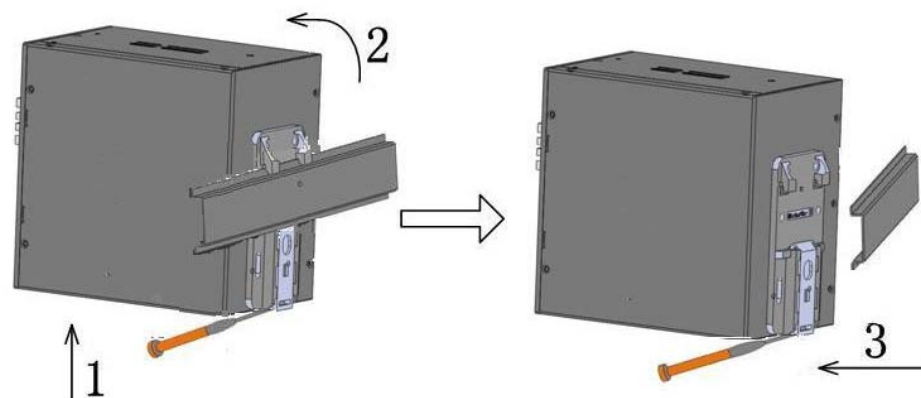

Figure 7 DIN-Rail Dismounting

- KIEN3016A Panel Mounting

The specific steps are as follows:

Step 1: Select the mounting position for KIEN3016A on the wall or in cabinet; ensure that there is adequate space for the switch.

Step 2: Drill 4 holes on the selected position according to the panel mounting dimension drawings; use a cross-screwdriver to screw 4 cross-slot screws (M3×10) into holes. Don't tighten the screws completely; leave about 5mm of space between.

Step 3: Aim 4 mounting holes on KIEN3016A mounting plate at 4 fixed screws; pass the screws through 4 holes with the diameter of 6.5mm (Φ6.5); then slide down KIEN3016A as seen below; finally screw 4 screws tightly. Now the KIEN3016A should be firmly fixed to the wall or cabinet.

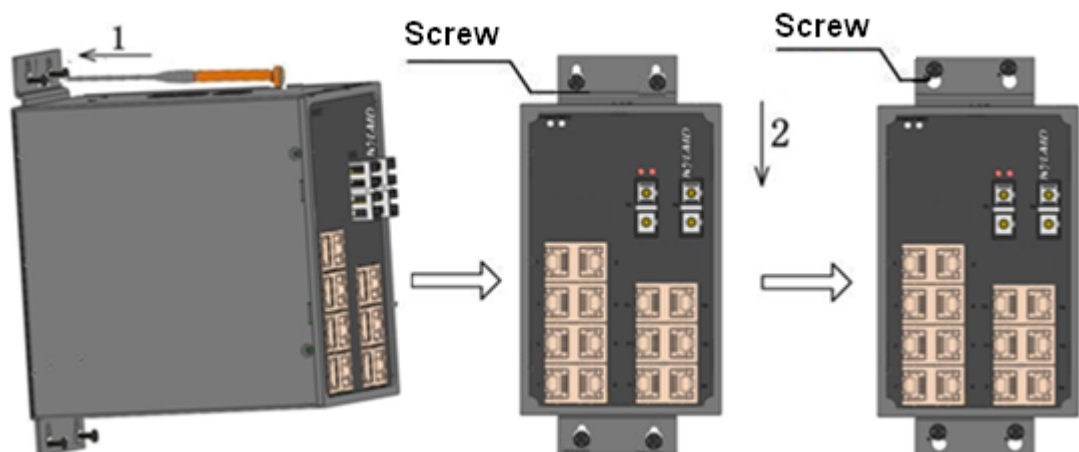

Figure 8 Panel Mounting

- Remove KIEN3016A from wall or cabinet

The specific steps are as follows:

Step 1: Use a screwdriver to loosen 4 screws; move the device up to let screws into 4 holes with the diameter of 6.5mm (Φ6.5).

Step 2: Unscrew the screws from wall or cabinet; remove the device from wall

or cabinet.

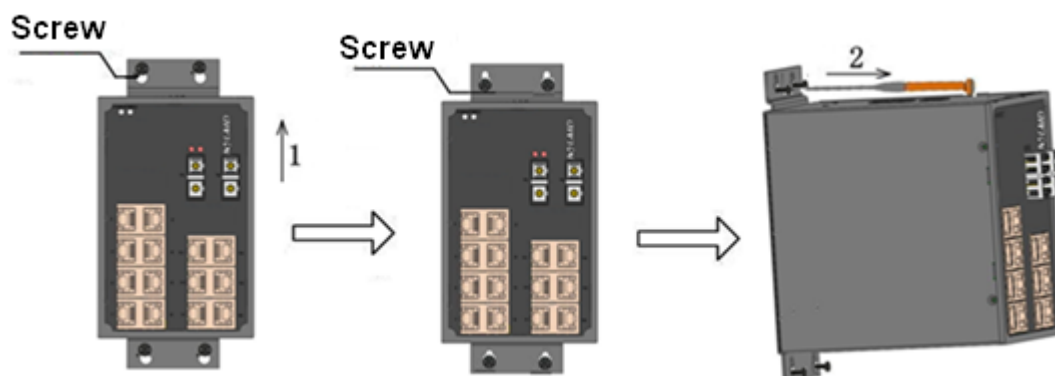

Figure 9 Panel Dismounting

## 5. Cable Connection

### 5.1 10/100Base-T(X)

10/100Base-T(X) Ethernet RJ45 port can be connected to terminal equipment and network devices with straight-through cables or crossover cables. RJ45 connectors must be attached at both ends of the cable.

- RJ45 port and pin number

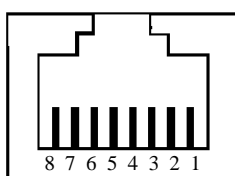

Figure 10 RJ45 Port

- Pin distribution of 10/100Base-T(X)

Table 1 Pin Distribution of 10/100Base-T(X)

Pin	MDI-X signal name	MDI signal name
1	Receiving data+(RD+)	Output data+(TD+)
2	Receiving data-(RD-)	Output data-(TD-)
3	Output data+(TD+)	Receiving data+(RD+)
6	Output data-(TD-)	Receiving data-(RD-)



Property		FX(FC/SC/ST)					
		2	5	40	60	60	80
Transmission Distance (Km)		2	5	40	60	60	80
Applicable Distance (Km)		0~2	0~5	0~40	6~60	4~60	10~80
Luminous power	Min. (dBm)	-19		-12	-8	-8	-8
	Max. (dBm)	-11		-4	0	-2	0
Receiving Sensitivity (dBm)		-31		-34	-34	-34	-34
Overload Luminous Power (dBm)		-3		-3	-3	-3	-3

- 100M fiber port wiring (Take SC port as example; ST/FC wiring method is the same with SC)

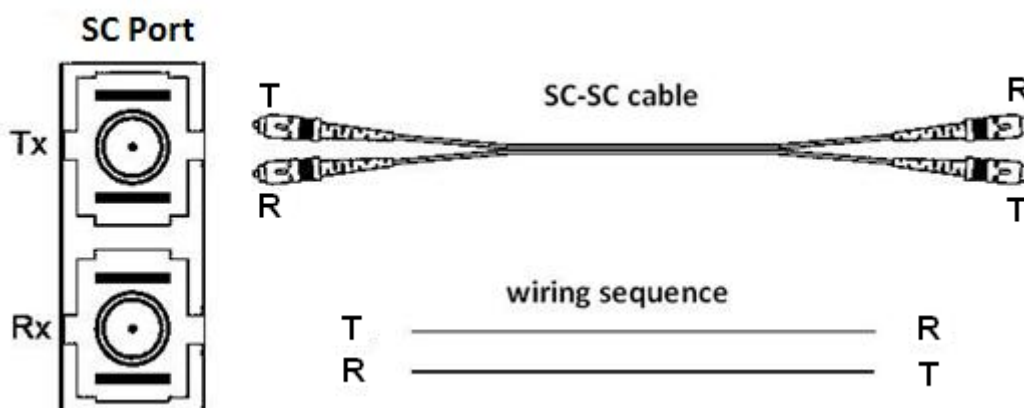

Figure 13 100M Fiber Port Wiring

**Note:** A laser is used to transmit signals in fiber cables. The laser meets the requirements of level 1 laser products. Routine operation is not harmful to your eyes, but do not look directly at the fiber port and fiber connector when the switch is powered on.

### 5.3 Power

According to the power input requirements, use a 5.08mm-spacing terminal block to connect the power cable.

**Note:** The cross section area of the power cable is required to be greater than 0.75mm<sup>2</sup> and less than 2.5mm<sup>2</sup>. The grounding resistance requirement: <5Ω.

- 5.08mm power terminal block pin number is shown in Figure 14

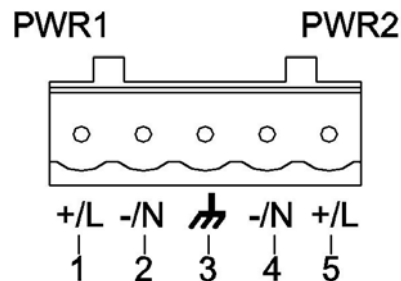

Figure 14 Pin 5.08mm Power Terminal Block

- 5.08mm power terminal block contact definition

Table 3 Contact Definition

Contact number	DC wiring definition	AC wiring definition
1	PWR1: +	PWR1: L
2	PWR1: -	PWR1: N
3	Protection Ground	Protection Ground
4	PWR2: -	PWR2: N
5	PWR2: +	PWR2: L

- Wiring and mounting

Step 1: Take the power terminal block off KIEN3016A

Step 2: Insert the power cable into the terminal block and fix the power cable

Step 3: Put the terminal block back to KIEN3016A with the connected cable

## 5.4 Grounding

- Chassis grounding and power terminal grounding

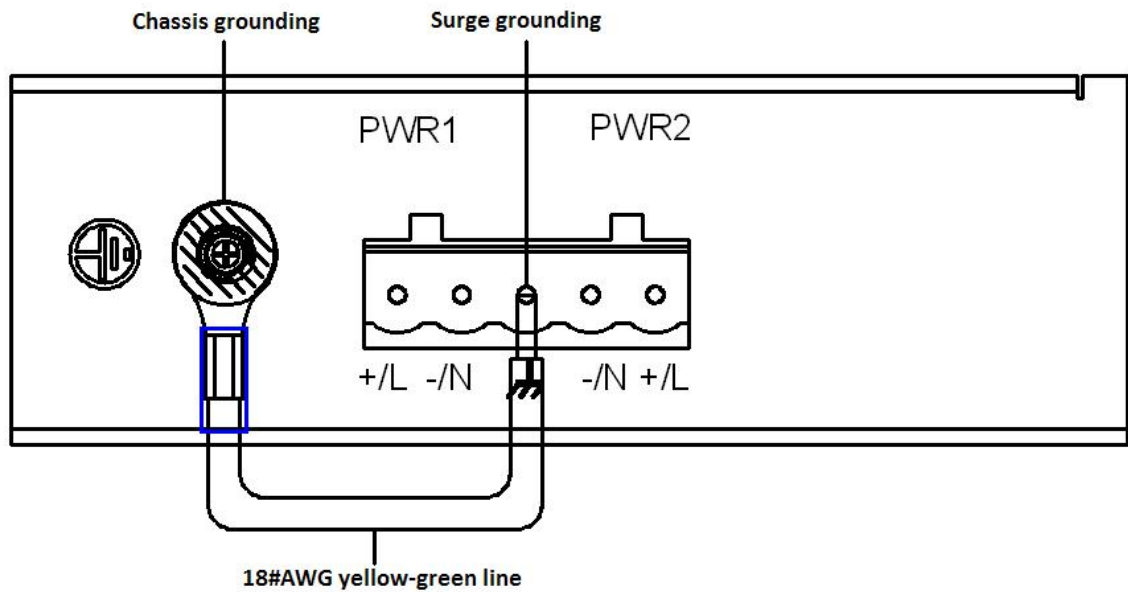

Figure 15 Chassis Grounding and Power Terminal Grounding

There is a grounding screw on the top panel of the KIEN3016A, which is for chassis grounding. One end of the chassis grounding cable is connected with the grounding screw and the other end of the cable is reliably grounded. (The cross section area of chassis grounding cable should be more than  $2.5\text{mm}^2$ . The grounding resistance requirement:  $<5\Omega$ )

The grounding part in the 5.08mm power terminal block is called surge grounding.

It is required to connect the chassis grounding part with the surge grounding part by an 18#AWG yellow-green line as seen below

- 18#AWG yellow-green line (Unit: mm)

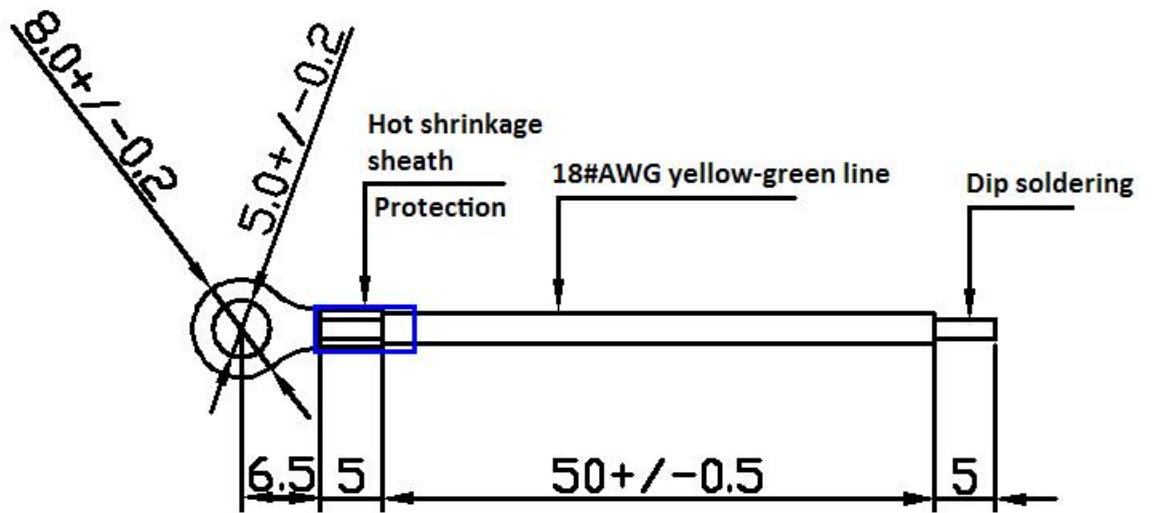

Figure 16 18#AWG Yellow-green Line

**Note:** If KIEN3016A needs to do a dielectric voltage withstand test, in order to ensure proper testing, please disconnect the 18#AWG yellow-green line to disable surge protection circuit that connects to surge grounding

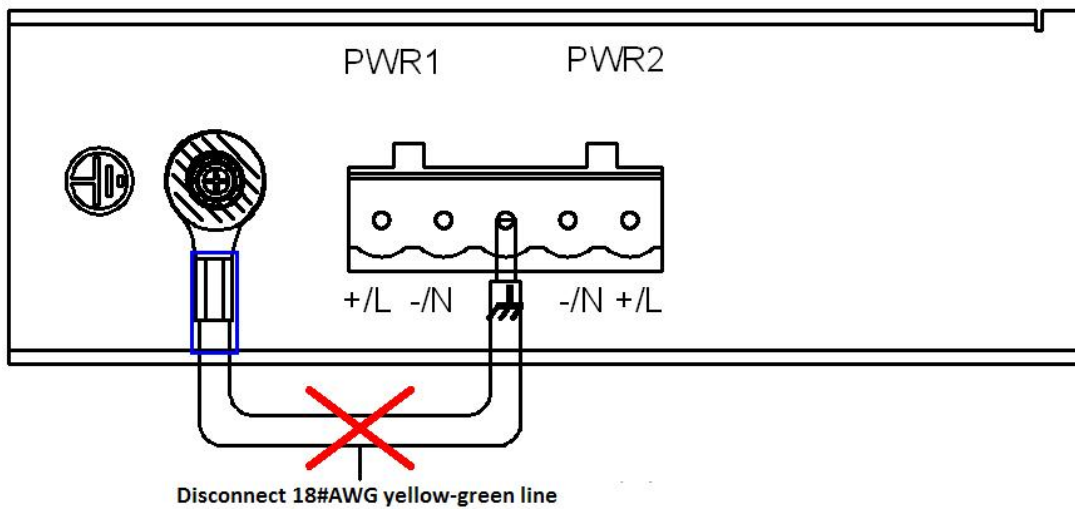

Figure 17 Disconnect 18#AWG Yellow-green Line

## 6. LED Indicators

Table 4 KIEN3016A LED Indicators



LED	State	Description
<b>Power LEDs</b>		
PWR1	ON	Power 1 connects and operates normally.
	OFF	Power 1 disconnects or operates abnormally.
PWR2	ON	Power 2 connects and operates normally.
	OFF	Power2 disconnects or operates abnormally.
<b>Ethernet RJ45 port LEDs</b>		
Each RJ45 Ethernet port has two indicators a yellow LED and a green LED. The yellow LED indicates port rate, while the green LED indicates port connection state.		
Speed (Yellow)	ON	100M working state
	OFF	10M working state or no connection
Link/Act (Green)	ON	Effective network connection in the port
	Blinking	Network activities in the port
	OFF	No effective network connection in the port
<b>100Base-FX LEDs</b>		
Link/Act	ON	Effective network connection in the port
	Blinking	Network activities in the port
	OFF	No effective network connection in the port

## 7. Product Models and Accessories

- The specific configuration models of KIEN3016A are shown in Table 5

Table 5 KIEN3016A Configuration Table

Model	Description	Power
KIEN3016A-16T	16 10/100Base-T(X)RJ45 Ports	12VDC(9~36VDC), 24VAC/DC(18~50VAC/18-72VDC), dual redundant power inputs
KIEN3016A-2S/M-14T	2 100Base-FX Fiber Ports, 1410/100Base-T(X) RJ45 Ports	

- The optional accessories of KIEN3016A are shown inTable 6

Table 6 KIEN3016A Optional Accessories

<b>Model</b>	<b>Description</b>
DT-BGAZ-02	Panel mounting kit
DT-FCZ-RJ45-01	RJ45 dustproof shield

## 8. Basic Features and Specifications

- **Cable**

Twisted Pair: 100m (Standard CAT5, CAT5e network cable)

Multi Mode Fiber: 1310nm, 5Km (100Mbps)

Single Mode Fiber: 1310nm, 40Km/60Km(100Mbps);  
1550nm, 60Km /80Km(100Mbps)

- **Power Requirements**

Power input: 12VDC (9~36VDC), 24VAC/DC (18~50VAC, 18~72VDC)

Power terminal: 5-pin 5.08mm-spacing plug-in terminal block

Power consumption:

KIEN3016A-16T:6.1W

KIEN3016A-2S/M-14T:6.6W

- **Physical Characteristics**

Housing: Metal, fanless

Installation: DIN-Rail or Panel mounting

Dimensions (W×H×D): 88mm×135mm×137mm

Weight: 1.2Kg

- **Environment Limits**

Operating Temperature: -40°C to 85°C (-40 to 185°F)

Storage Temperature: -40°C to 85°C (-40 to 185°F)

Ambient Relative Humidity: 5% to 95% (non-condensing)

- **MTBF:** 361000h
- **Warranty:** 5 years